

Degrees of protection provided by enclosures (IP code)

<http://www.china-gauges.com/>

ICS 29.100.99; 29.120.99

National foreword

This British Standard is the UK implementation of EN 60529:1992+A2:2013. It is identical to IEC 60529:1989, incorporating amendment 2:2013. It supersedes BS EN 60529:1992, which is withdrawn.

The start and finish of text introduced or altered by amendment is indicated in the text by tags. Tags indicating changes to IEC text carry the number of the IEC amendment. For example, text altered by IEC amendment 2 is indicated by A2 A2 .

The UK participation in its preparation was entrusted to Technical Committee GEL/70, Protective enclosures of electrical apparatus.

A list of organizations represented on this committee can be obtained on request to its secretary.

Annexes designated “informative” are part of the body of the standard whilst annexes designated “informative” are given for information only. National appendices are designated “informative”.

The foreword of EN 60529 makes reference to the “date of withdrawal” (dow) of the relevant national standard. In this case the relevant national standard is BS 5490 which was withdrawn on 1 July 1992.

The publication does not purport to include all the necessary provisions of a contract. Users are responsible for its correct application.

Compliance with a British Standard cannot confer immunity from legal obligations.

This British Standard was published under the authority of the Standards Board and comes into effect on 31 January 1992

© The British Standards Institution 2013.
Published by BSI Standards Limited 2013

Amendments/corrigenda issued since publication

Amd. No.	Date	Comments
7643	July 1993	
10931	August 2000	Indicated by a sideline
	31 October 2013	Implementation of IEC amendment 2:2013 with CENELEC endorsement A2:2013

UDC 621.3:62-78:620.1

Descriptors: Electric equipment, protection, enclosure, type test, marking

English version

Degrees of protection provided by enclosures (IP code)

(includes amendment A1:2000)
(IEC 60529:1989 + A1:1999)

Degrés de protection procurés par les
enveloppes (Code IP)
(inclut l'amendement A1:2000)
(CEI 60529:1989 + A1:1999)

Schutzarten durch Gehäuse (IP-Code)
(enthält Änderung A1:2000)
(IEC 529:1989 + A1:1999)

This European Standard was approved by CENELEC on 25 June 1991; amendment A1 was approved by CENELEC on 2000-01-01. CENELEC members are bound to comply with the CEN/CENELEC Internal Regulations which stipulate the conditions for giving this European Standard the status of a national standard without any alteration.

Up-to-date lists and bibliographical references concerning such national standards may be obtained on application to the Central Secretariat or to any CENELEC member.

This European Standard exists in three official versions (English, French, German). A version in any other language made by translation under the responsibility of a CENELEC member into its own language and notified to the Central Secretariat has the same status as the official versions.

CENELEC members are the national standards bodies of Austria, Belgium, Denmark, Finland, France, Germany, Greece, Iceland, Ireland, Italy, Luxembourg, Netherlands, Norway, Portugal, Spain, Sweden, Switzerland and United Kingdom.

CENELEC

European Committee for Electrotechnical Standardization
Comité Européen de Normalisation Electrotechnique
Europäisches Komitee für Elektrotechnische Normung

Central Secretariat: rue de Stassart 35, B-1050 Brussels

Foreword

The CENELEC questionnaire procedure, performed for finding out whether or not the International Standard IEC 529:1989 could be accepted without textual changes, has shown that no CENELEC common modifications were necessary for the acceptance as a European Standard.

The reference document was submitted to the CENELEC members for formal vote and was approved by CENELEC as EN 60529 on 25 June 1991.

This European Standard supersedes HD 365 S3:1985.

The following dates were fixed:

- latest date of publication of an identical national standard (dop)1992-07-01
- latest date of withdrawal of conflicting national standards (dow)1992-07-01

For products not covered by a specific product standard which have complied with HD 365 S3:1985 before 1992-07-01, as shown by the manufacturer or by a certification body, this previous standard may continue to apply for production until 1997-07-01.

Annexes designated “normative” are part of the body of the standard. In this standard, annex ZA is normative.

Endorsement notice

The text of the International Standard IEC 529:1989 was approved by CENELEC as a European Standard without any modification.

Foreword to amendment A1

The text of document 70/91/FDIS, future amendment 1 to IEC 60529, prepared by IEC TC 70, Degrees of protection by enclosures, was submitted to the IEC-CENELEC parallel vote and was approved by CENELEC as amendment A1 to EN 60529:1991 on 2000-01-01.

The following dates were fixed:

- latest date by which the amendment has to be implemented at national level by publication of an identical national standard or by endorsement (dop)2000-10-01

- latest date by which the national standards conflicting with the amendment have to be withdrawn

Annexes designated “normative” are part of the body of the standard.

In this standard, Annex ZA is normative.

Annex ZA has been added by CENELEC.

Foreword to amendment A2

The text of document 70/122/CDV, future IEC 60529:1989/A2, prepared by IEC/TC 70 “Degrees of protection provided by enclosures” was submitted to the IEC-CENELEC parallel vote and approved by CENELEC as EN 60529:1991/A2:2013.

The following dates are fixed:

- latest date by which the document has to be implemented at national level by publication of an identical national standard or by endorsement (dop) 2014-07-03
- latest date by which the national standards conflicting with the document have to be withdrawn (dow) 2016-10-03

Attention is drawn to the possibility that some of the elements of this document may be the subject of patent rights. CENELEC [and/or CEN] shall not be held responsible for identifying any or all such patent rights.

This standard covers the Principle Elements of the Safety Objectives for Electrical Equipment Designed for Use within Certain Voltage Limits (LVD – 2006/95/EC).

Endorsement notice

The text of the International Standard IEC 60529:1989/A2:2013 was approved by CENELEC as a European Standard without any modification.

Contents

	Page	Page
Introduction	5	Figure 4 — Test device to verify protection against spraying and splashing water; second characteristic numerals 3 and 4 (oscillating tube)
1 Scope and object	5	27
2 Normative references	5	Figure 5 — Hand held test device to verify protection against spraying and splashing water; second characteristic numerals 3 and 4 (spray nozzle)
3 Definitions	6	28
4 Designations	7	Figure 6 — Test device to verify protection against water jets (hose nozzle)
5 Degrees of protection against access to hazardous parts and against solid foreign objects indicated by the first characteristic numeral	7	29
6 Degrees of protection against ingress of water indicated by the second characteristic numeral	10	Figure 7 — Fan jet nozzle dimensions
7 Degrees of protection against access to hazardous parts indicated by the additional letter	12	Figure 8 — Fan jet nozzle resulting dimensions of spraying hole for checking purpose
8 Supplementary letters	13	31
9 Examples of designations with the IP Code	14	Figure 9 — Fan jet nozzle examples
10 Marking	15	32
11 General requirements for tests	15	Figure 10 — Set-up for measuring the impact force of the water jet for determining the protection against high-pressure and temperature water jet, degree of protection against ingress of water IP X9
12 Tests for protection against access to hazardous parts indicated by the first characteristic numeral	16	33
13 Tests for protection against solid foreign objects indicated by the first characteristic numeral	18	Figure 11 — Impact force distribution
14 Tests for protection against water indicated by the second characteristic numeral	20	34
15 Tests for protection against access to hazardous parts indicated by the additional letter	23	Figure 12 — Test device to verify protection against high pressure and temperature water jet for small enclosures
Annex A (informative) Examples of IP Coding for the verification of protection of low-voltage equipment against access to hazardous parts	36	35 ^{A2}
Annex B (informative) Summary of responsibilities of relevant Technical Committees	42	Table I — Degrees of protection against access to hazardous parts indicated by the first characteristic numeral
Annex ZA (normative) Other international publications quoted in this standard with the references of the relevant European publications	43	9
Figure 1 — Jointed test finger	24	Table II — Degrees of protection against solid foreign objects indicated by the first characteristic numeral
Figure 2 — Test device to verify protection against dust (dust chamber)	25	10
Figure 3 — Test device to verify protection against vertically falling water drops (drip box)	26	Table III — Degrees of protection against water indicated by the second characteristic numeral
		12
		Table IV — Degrees of protection against access to hazardous parts indicated by the additional letter
		13
		Table V — Test conditions for degrees of protection indicated by the first characteristic numeral
		16
		Table VI — Access probes for the tests for protection of persons against access to hazardous parts
		17
		Table VII — Test means for the tests for protection against solid foreign objects
		18
		Table VIII — Test means and main test conditions for the tests for protection against water
		20
		Table IX — Total water flow rate q_v under IPX3 and IPX4 test conditions
		22
		Mean flow rate per hole $q_{v1} = 0,07$ l/min

<http://www.china-gauges.com/>

Introduction

This standard describes a system for classifying the degrees of protection provided by the enclosures of electrical equipment. Whilst this system is suitable for use with most types of electrical equipment, it should not be assumed that all the listed degrees of protection are applicable to a particular type of equipment. The manufacturer of the equipment should be consulted to determine the degrees of protection available and the parts of equipment to which the stated degree of protection applies.

The adoption of this classification system, wherever possible, will promote uniformity in methods of describing the protection provided by the enclosure and in the tests to prove the various degrees of protection. It should also reduce the number of types of test devices necessary to test a wide range of products.

This second edition of IEC 529 takes account of experiences with the first edition, and clarifies the requirements. It provides for an optional extension of the IP Code by an additional letter A, B, C, or D if the actual protection of persons against access to hazardous parts is higher than that indicated by the first characteristic numeral.

In general, enclosures with an IP coding to the first edition would be eligible for the same code according to this edition.

1 Scope and object

This standard applies to the classification of degrees of protection provided by enclosures for electrical equipment with a rated voltage not exceeding 72,5 kV.

The object of this standard is to give:

- a) *Definitions* for degrees of protection provided by enclosures of electrical equipment as regards:
 - 1) protection of persons against access to hazardous parts inside the enclosure;
 - 2) protection of the equipment inside the enclosure against ingress of solid foreign objects;
 - 3) protection of the equipment inside the enclosure against harmful effects due to the ingress of water.
- b) *Designations* for these degrees of protection.
- c) *Requirements* for each designation.
- d) *Tests* to be performed to verify that the enclosure meets the requirements of this standard.

It will remain the responsibility of individual Technical Committees to decide on the extent and

manner in which the classification is used in their standards and to define "enclosure" as it applies to their equipment. However, it is recommended that for a given classification the tests do not differ from those specified in this standard. If necessary, complementary requirements may be included in the relevant product standard. A guide for the details to be specified in relevant product standards is given in Annex B.

For a particular type of equipment, a Technical Committee may specify different requirements provided that at least the same level of safety is ensured.

This standard deals only with enclosures that are in all other respects suitable for their intended use as specified in the relevant product standard and which from the point of view of materials and workmanship ensure that the claimed degrees of protection are maintained under the normal conditions of use.

This standard is also applicable to empty enclosures provided that the general test requirements are met and that the selected degree of protection is suitable for the type of equipment to be protected.

Measures to protect both the enclosure and the equipment inside the enclosure against external influences or conditions such as

- mechanical impacts
- corrosion
- corrosive solvents (e.g. cutting liquids)
- fungus
- vermin
- solar radiation
- icing
- moisture (e.g. produced by condensation)
- explosive atmospheres

and the protection against contact with hazardous moving parts external to the enclosure (such as fans),

are matters for the relevant product standard.

Barriers external to the enclosure and not attached to it and obstacles which have been provided solely for the safety of personnel are not considered as a part of the enclosure and are not dealt with in this standard.

2 Normative references

The following normative documents contain provisions which, through reference in this text, constitute provisions of this International Standard. For dated references, subsequent amendments to, or revisions of, any of these publications do not apply. However, parties to agreements based on this

International Standard are encouraged to investigate the possibility of applying the most recent editions of the normative documents indicated below. For undated references, the latest edition of the normative document referred to applies. Members of IEC and ISO maintain registers of currently valid International Standards. IEC 60050-195:1998, *International Electrotechnical Vocabulary (IEV): Part 195: Earthing and protection against electric shock*.

IEC 60050(826):1992, *International Electrotechnical Vocabulary (IEV): Chapter 826: Electrical installations of buildings*

IEC 60068-1:1988, *Environmental testing Part 1: General and guidance*.

IEC 60068-2-68:1984, *Environmental testing — Part 2: Tests — Test L: Dust and sand*.

IEC 60071-2:1996, *Insulation co-ordination — Part 2: Application guide*.

3 Definitions

For the purpose of this standard, the following definitions apply:

3.1 enclosure

a part providing protection of equipment against certain external influences and, in any direction, protection against direct contact (IEV 826-03-12)¹⁾

NOTE This definition taken from the existing International Electrotechnical Vocabulary (IEV) needs the following explanations under the scope of this standard:

- 1) Enclosures provide protection of persons or livestock against access to hazardous parts.
- 2) Barriers, shapes of openings or any other means – whether attached to the enclosure or formed by the enclosed equipment – suitable to prevent or limit the penetration of the specified test probes are considered as a part of the enclosure, except when they can be removed without the use of a key or tool.

3.2 direct contact

contact of persons or livestock with live parts (IEV 826-03-05)

NOTE This IEV definition is given for information. In this standard “Direct contact” is replaced by “Access to hazardous parts”.

3.3 degree of protection

the extent of protection provided by an enclosure against access to hazardous parts, against ingress of solid foreign objects and/or against ingress of water and verified by standardized test methods

3.4 IP Code

a coding system to indicate the degrees of protection provided by an enclosure against access to hazardous parts, ingress of solid foreign objects, ingress of water and to give additional information in connection with such protection

3.5 Hazardous part

A part that is hazardous to approach or touch.

3.5.1 hazardous live part

a live part which, under certain conditions of external influences, can give an electric shock (see IEC 60050-195, 195-06-05)

3.5.2 hazardous mechanical part

a moving part, other than a smooth rotating shaft, that is hazardous to touch

3.6 protection provided by an enclosure against access to hazardous parts

the protection of persons against

- contact with hazardous low-voltage live parts,
- contact with hazardous mechanical parts,
- approach to hazardous high-voltage live parts below adequate clearance inside an enclosure

NOTE This protection may be provided

- by means of the enclosure itself,
- by means of barriers as part of the enclosure or distances inside the enclosure.

3.7 adequate clearance for protection against access to hazardous parts

a distance to prevent contact or approach of an access probe to a hazardous part

3.8 access probe

a test probe simulating in a conventional manner a part of a person or a tool, or the like, held by a person to verify adequate clearance from hazardous parts

3.9 object probe

a test probe simulating a solid foreign object to verify the possibility of ingress into an enclosure

3.10 opening

a gap or aperture in an enclosure which exists or may be formed by the application of a test probe at the specified force

¹⁾ IEC 50(826).

4 Designations

The degree of protection provided by an enclosure is indicated by the IP Code in the following way:

4.1 Arrangement of the IP Code

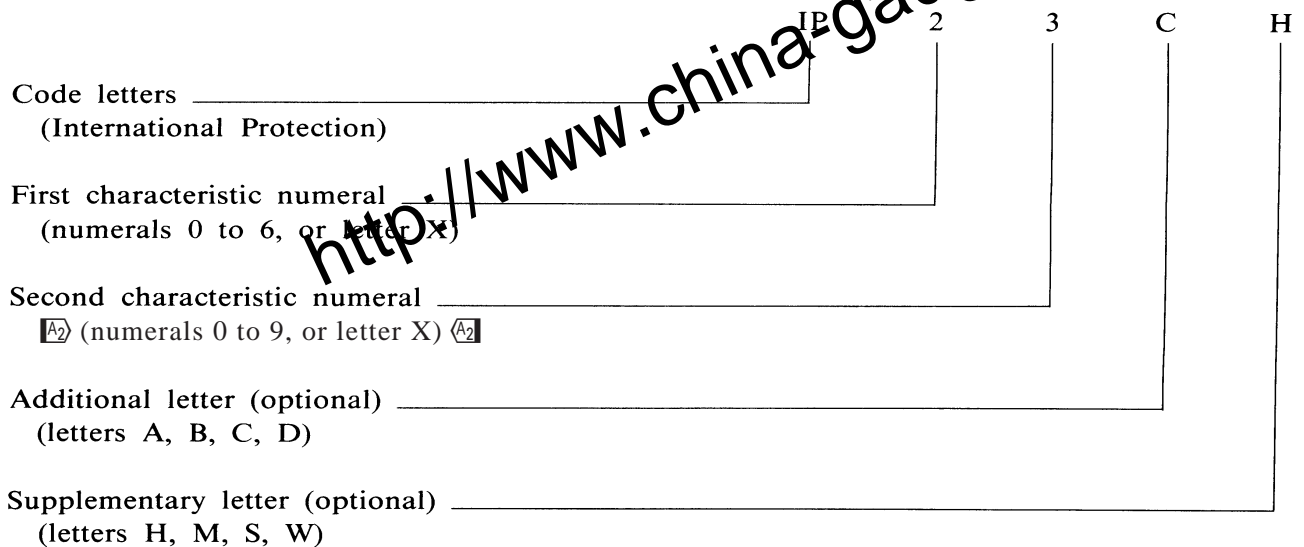

Where a characteristic numeral is not required to be specified, it shall be replaced by the letter “X” (“XX” if both numerals are omitted).

Additional letters and/or supplementary letters may be omitted without replacement.

Where more than one supplementary letter is used, the alphabetic sequence shall apply.

If an enclosure provides different degrees of protection for different intended mounting arrangements, the relevant degrees of protection shall be indicated by the manufacturer in the instructions related to the respective mounting arrangements.

Details for the marking of an enclosure are given in Clause 10.

4.2 Elements of the IP Code and their meanings

A brief description of the IP Code elements is given in the following chart. Full details are specified in the clauses indicated in the last column.

4.3 Examples for the use of letters in the IP Code

The following examples are to explain the use and arrangement of letters in the IP Code.

For more comprehensive examples see Clause 9.

- IP44 – no letters, no options;
- IPX5 – omitting first characteristic numeral;
- IP2X – omitting second characteristic numeral;
- IP20C – using additional letter;

IPXXC – omitting both characteristic numerals, using additional letter;

IPX1C – omitting first characteristic numeral, using additional letter;

IP3XD – omitting second characteristic numeral, using additional letter;

IP23S – using supplementary letter;

IP21CM – using additional letter and supplementary letter;

Ⓐ IPX5/IPX7/IPX9 – giving three degrees of protection by an enclosure against water jets, temporary immersion and high pressure and temperature water jet for a “versatile” application. Ⓐ

5 Degrees of protection against access to hazardous parts and against solid foreign objects indicated by the first characteristic numeral

The designation with a first characteristic numeral implies that conditions stated in both 5.1 and 5.2 are met.

The first characteristic numeral indicates that:

- the enclosure provides protection of persons against access to hazardous parts by preventing or limiting the ingress of a part of the human body or an object held by a person; and simultaneously
- the enclosure provides protection of equipment against the ingress of solid foreign objects.

An enclosure shall only be designated with a stated degree of protection indicated by the first characteristic numeral if it also complies with all lower degrees of protection.

However, the tests establishing compliance with any one of the lower degrees of protection need not necessarily be carried out provided that these tests would obviously be met if applied.

5.1 Protection against access to hazardous parts

Table I gives brief descriptions and definitions for the degrees of protection against access to hazardous parts.

Element	Numerals or letters	Meaning for the protection of equipment	Meaning for the protection of persons	Ref.
Code letters	IP	—	—	—
First characteristic Numeral	0 1 2 3 4 5 6	Against ingress of solid foreign objects (non-protected) ≥50 mm diameter ≥12,5 mm diameter ≥2,5 mm diameter ≥1,0 mm diameter dust-protected dust-tight	Against access to hazardous parts with (non-protected) back of hand finger tool wire wire wire	Cl. 5
Second characteristic numeral	0 1 2 3 4 5 6 7 8 A ₂ 9 A ₂	Against ingress of water with harmful effects (non-protected) vertically dripping dripping (15° tilted) spraying splashing jetting powerful jetting temporary immersion continuous immersion A ₂ high pressure and temperature water jet A ₂	—	Cl. 6
Additional letter (optional)	A B C D	—	Against access to hazardous parts with: back of hand finger tool wire	Cl. 7
Supplementary letter (optional)	H M S W	Supplementary information specific to: High-voltage apparatus Motion during water test Stationary during water test Weather conditions	—	Cl. 8

Table I — Degrees of protection against access to hazardous parts indicated by the first characteristic numeral

First characteristic numeral	Degree of protection		Test conditions, see
	Brief description	Definition	
0	Non-protected	—	—
1	Protected against access to hazardous parts with the back of a hand	The access probe, sphere of 50 mm Ø, shall have adequate clearance from hazardous parts	12.2
2	Protected against access to hazardous parts with a finger	The jointed test finger of 12 mm Ø, 80 mm length, shall have adequate clearance from hazardous parts	12.2
3	Protected against access to hazardous parts with a tool	The access probe of 2,5 mm Ø shall not penetrate	12.2
4	Protected against access to hazardous parts with a wire	The access probe of 1,0 mm Ø shall not penetrate	12.2
5	Protected against access to hazardous parts with a wire	The access probe of 1,0 mm Ø shall not penetrate	12.2
6	Protected against access to hazardous parts with a wire	The access probe of 1,0 mm Ø shall not penetrate	12.2

NOTE In the case of the first characteristic numerals 3, 4, 5 and 6, protection against access to hazardous parts is satisfied if adequate clearance is kept. The adequate clearance should be specified by the relevant product committee in accordance with **12.3**

Due to the simultaneous requirement specified in Table II, the definition “shall not penetrate” is given in Table I.

Degrees of protection listed in this table shall be specified only by the first characteristic numeral and not by reference to the brief description or definition.

To comply with the conditions of the first characteristic numeral, adequate clearance shall be kept between the access probe and hazardous parts.

The tests are specified in Clause **12**.

5.2 Protection against solid foreign objects

Table II gives brief descriptions and the definitions for the degrees of protection against the penetration of solid foreign objects including dust.

Degrees of protection listed in this table shall only be specified by the first characteristic numeral and not by reference to the brief description or definition.

The protection against the ingress of solid foreign objects implies that the object probes up to numeral 2 in Table II shall not fully penetrate the enclosure. This means that the full diameter of the sphere shall not pass through an opening in the enclosure. Object probes for numerals 3 and 4 shall not penetrate the enclosure at all.

Dust-protected enclosures to numeral 5 allow a limited quantity of dust to penetrate under certain conditions.

Dust-tight enclosures to numeral 6 do not allow any dust to penetrate.

NOTE Enclosures assigned a first characteristic numeral of 1 to 4 generally exclude both regularly and irregularly shaped solid foreign objects provided that three mutually perpendicular dimensions of the object exceed the appropriate figure in column 3 of **Table II**.

The tests are specified in Clause **13**.

Table II — Degrees of protection against solid foreign objects indicated by the first characteristic numeral

First characteristic numeral	Degree of protection		Test conditions, see
	Brief description	Definition	
0	Non-protected	—	—
1	Protected against solid foreign objects of 50 mm Ø and greater	The object probe, sphere of 50 mm Ø, shall not fully penetrate ^a	13.2
2	Protected against solid foreign objects of 12,5 mm Ø and greater	The object probe, sphere of 12,5 mm, Ø shall not fully penetrate ^a	13.2
3	Protected against solid foreign objects of 2,5 mm Ø and greater	The object probe of 2,5 mm Ø shall not penetrate at all ^a	13.2
4	Protected against solid foreign objects of 1,0 mm Ø and greater	The object probe of 1,0 mm Ø shall not penetrate at all ^a	13.2
5	Dust-protected	Ingress of dust is not totally prevented, but dust shall not penetrate in a quantity to interfere with satisfactory operation of the apparatus or to impair safety	13.4 13.5
6	Dust-tight	No ingress of dust	13.4 13.6

^a The full diameter of the object probe shall not pass through an opening of the enclosure.

6 Degrees of protection against ingress of water indicated by the second characteristic numeral

The second characteristic numeral indicates the degree of protection provided by enclosures with respect to harmful effects on the equipment due to the ingress of water.

A2 The tests for the second characteristic numeral are carried out with fresh water. The actual protection may not be satisfactory if cleaning operations with high pressure and temperature water jet outside the requirements of second characteristic numeral 9 and/or solvents are used. **A2**

Table III gives brief descriptions and definitions of the protection for the degrees represented by the second characteristic numeral.

Degrees of protection listed in this table shall be specified only by the second characteristic numeral and not by reference to the brief description or definition.

The tests are specified in Clause 14.

Up to and including second characteristic numeral 6, the designation implies compliance also with the requirements for all lower characteristic numerals. However, the tests establishing compliance with any one of the lower degrees of protection need not necessarily be carried out provided that these tests obviously would be met if applied.

A2 An enclosure designated with second characteristic numeral 9 only is considered unsuitable for exposure to water jets (designated by second characteristic numeral 5 or 6) and immersion in water (designated by second characteristic numeral 7 or 8) and need not comply with requirements for numeral 5, 6, 7 or 8 unless it is multiple coded as follows: **A2**

A2

Enclosure passes test for:		Designation and marking	Range of application
Water jets second characteristic numeral	Temporary/continuous immersion second characteristic numeral		
5	7	IPX5/IPX7	Versatile
5	8	IPX5/IPX8	Versatile
6	7	IPX6/IPX7	Versatile
6	8	IPX6/IPX8	Versatile
9	–	IPX7/IPX9	Versatile
9	8	IPX8/IPX9	Versatile
5 and 9	7	IPX5/IPX7/IPX9	Versatile
5 and 9	8	IPX5/IPX8/IPX9	Versatile
6 and 9	7	IPX6/IPX7/IPX9	Versatile
6 and 9	8	IPX6/IPX8/IPX9	Versatile
–	7	IPX7	Restricted
–	8	IPX8	Restricted
9	–	IPX9	Restricted
5 and 9	–	IPX5/IPX9	Versatile
6 and 9	–	IPX6/IPX9	Versatile

A2

Enclosures for “versatile” application indicated in the last column shall meet requirements for exposure to both water jets and temporary or continuous immersion.

A2 Enclosures for “restricted” application indicated in the last column are considered suitable only for the conditions to which they were tested. A2

Table III — Degrees of protection against water indicated by the second characteristic numeral

Second characteristic numeral	Degree of protection		Test conditions, see
	Brief description	Definition	
0	Non-protected	—	—
1	Protected against vertically falling water drops	Vertically falling drops shall have no harmful effects	14.2.1
2	Protected against vertically falling water drops when enclosure tilted up to 15°	Vertically falling drops shall have no harmful effects when the enclosure is tilted at any angle up to 15° on either side of the vertical	14.2.2
3	Protected against spraying water	Water sprayed at an angle up to 60° on either side of the vertical shall have no harmful effects	14.2.3
4	Protected against splashing water	Water splashed against the enclosure from any direction shall have no harmful effects	14.2.4
5	Protected against water jets	Water projected in jets against the enclosure from any direction shall have no harmful effects	14.2.5
6	Protected against powerful water jets	Water projected in powerful jets against the enclosure from any direction shall have no harmful effects	14.2.6
7	Protected against the effects of temporary immersion in water	Ingress of water in quantities causing harmful effects shall not be possible when the enclosure is temporarily immersed in water under standardized conditions of pressure and time	14.2.7
8	Protected against the effects of continuous immersion in water	Ingress of water in quantities causing harmful effects shall not be possible when the enclosure is continuously immersed in water under conditions which shall be agreed between manufacturer and user but which are more severe than for numeral 7	14.2.8
A_2 9	Protected against high pressure and temperature water jets	Water projected at high pressure and high temperature against the enclosure from any direction shall not have harmful effects	14.2.9

7 Degrees of protection against access to hazardous parts indicated by the additional letter

The additional letter indicates the degree of protection of persons against access to hazardous parts.

Additional letters are only used

- if the actual protection against access to hazardous parts is higher than that indicated by the first characteristic numeral

— or if only the protection against access to hazardous parts is indicated, the first characteristic numeral being then replaced by an X.

For example, such higher protection may be provided by barriers, suitable shape of openings or distances inside the enclosure.

Table IV gives access probes considered by convention as representative of parts of the human body or objects held by a person and the definitions for the degrees of protection against access to hazardous parts, indicated by additional letters.

Table IV — Degrees of protection against access to hazardous parts indicated by the additional letter

Additional letter	Degree of protection		Test conditions, see
	Brief description	Definition	
A	Protected against access with the back of the hand	The access probe, sphere of 50 mm Ø, shall have adequate clearance from hazardous parts	15.2
B	Protected against access with a finger	The jointed test finger of 12 mm Ø, 80 mm length, shall have adequate clearance from hazardous parts	15.2
C	Protected against access with a tool	The access probe of 2,5 mm Ø, 100 mm length, shall have adequate clearance from hazardous parts	15.2
D	Protected against access with a wire	The access probe of 1,0 mm Ø, 100 mm length, shall have adequate clearance from hazardous parts	15.2

An enclosure shall only be designated with a stated degree of protection indicated by the additional letter if the enclosure also complies with all lower degrees of protection. However, the tests establishing compliance with any one of the lower degrees of protection need not necessarily be carried out provided that these tests obviously would be met if applied.

The tests are specified in Clause 15.

See Annex A for examples of the IP Coding.

8 Supplementary letters

In the relevant product standard, supplementary information may be indicated by a supplementary letter following the second characteristic numeral or the additional letter.

Such exceptional cases shall conform with the requirements of this basic safety standard and the product standard shall state clearly the additional procedure to be carried out during tests for such a classification.

The letters listed below have already been designated and have the significance as stated:

Letter	Significance
H	High-voltage apparatus
M	Tested for harmful effects due to the ingress of water when the movable parts of the equipment (e.g. the rotor of a rotating machine) are in motion
S	Tested for harmful effects due to the ingress of water when the movable parts of the equipment (e.g. the rotor of a rotating machine) are stationary
W	Suitable for use under specified weather conditions and provided with additional protective features or processes

NOTE In the first edition of IEC 529 the letter "W" with the same meaning was placed immediately after the code letters "IP".

Other letters may be used in product standards.²⁾ The absence of the letters S and M implies that the degree of protection does not depend on whether parts of the equipment are in motion or not. This may necessitate tests being done under both conditions. However, the test establishing compliance with one of these conditions is generally sufficient, provided that the test in the other condition obviously would be met if applied.

²⁾ However, in order to avoid any duplicate use of supplementary letters the Secretariat of Technical Committee No. 70 should be consulted before any new letter is introduced by another Technical Committee.

9 Examples of designations with the IP Code

9.1 IP Code not using optional letters:

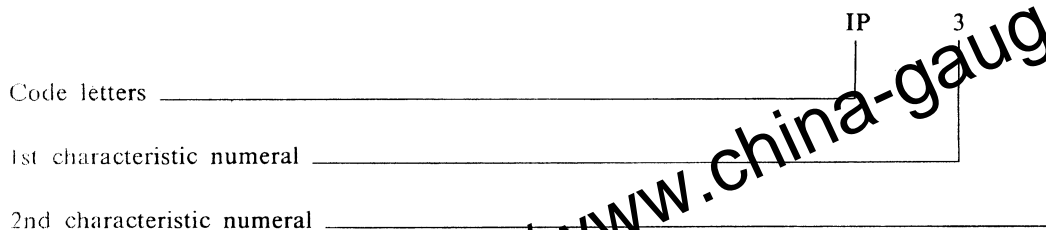

An enclosure with this designation (IP Code) (3) – protects persons, handling tools having a diameter of 2,5 mm and greater, against access to hazardous parts;

– protects the equipment inside the enclosure against ingress of solid foreign objects having a diameter of 2,5 mm and greater;

(4) – protects the equipment inside the enclosure against harmful effects due to water splashed against the enclosure from any direction.

9.2 IP Code using optional letters:

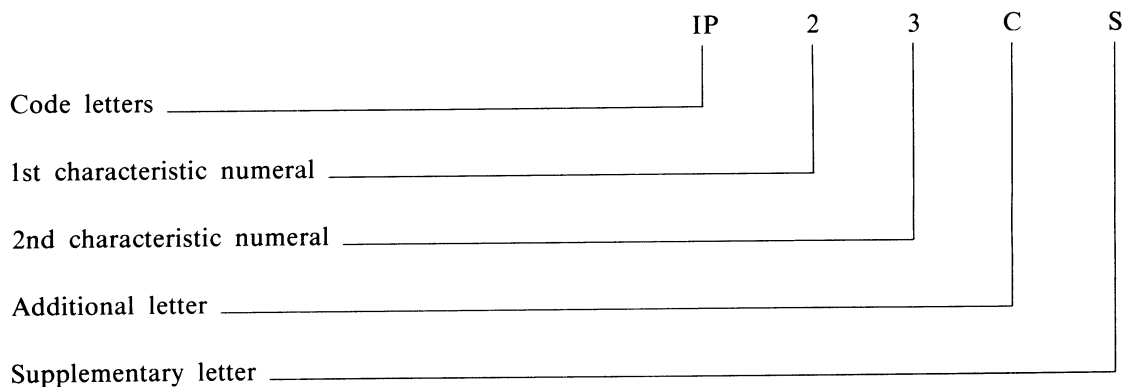

An enclosure with this designation (IP Code)

(2) – protects persons against access to hazardous parts with fingers;

– protects the equipment inside the enclosure against ingress of solid foreign objects having a diameter of 12,5 mm and greater;

(3) – protects the equipment inside the enclosure against the harmful effects due to water sprayed against the enclosure;

(C) – protects persons handling tools having a diameter of 2,5 mm and greater and a length not exceeding 100 mm against access to hazardous parts (the tool may penetrate the enclosure up to its full length);

(S) – is tested for protection against harmful effects due to the ingress of water when all the parts of the equipment are stationary.

10 Marking

The requirements for marking shall be specified in the relevant product standard.

Where appropriate, such a standard should also specify the method of marking which is to be used when

- one part of an enclosure has a different degree of protection to that of another part of the same enclosure;
- the mounting position has an influence on the degree of protection;
- the maximum immersion depth and time are indicated.

11 General requirements for tests

11.1 Atmospheric conditions for water or dust tests

Unless otherwise specified in the relevant product standard, the tests should be carried out under the standard atmospheric conditions described in IEC 68-1.

The recommended atmospheric conditions during the tests are as follows:

Temperature range:	15 °C to 35 °C
Relative humidity:	25% to 75%
Air pressure:	86 kPa to 106 kPa (860 mbar to 1 060 mbar).

11.2 Test samples

The tests specified in this standard are type tests.

Unless otherwise specified in a relevant product standard, the test samples for each test shall be in a clean and new condition, with all parts in place and mounted in the manner stated by the manufacturer.

If it is impracticable to test the complete equipment, representative parts or smaller equipment having the same full-scale design details shall be tested.

The relevant product standard shall specify details such as:

- the number of samples to be tested;
- conditions for mounting, assembling and positioning of the samples, for example by the use of an artificial surface (ceiling, floor or wall);

NOTE This also applies to equipment intended to be united with other relevant equipment, e.g. components which can be used either alone or in an assembly;

- the pre-conditioning, if any, which is to be used;
- whether to be tested energized or not;
- whether to be tested with its parts in motion or not.

In the absence of such specification, the manufacturer's instructions shall apply.

11.3 Application of test requirements and interpretation of test results

The application of the general requirements for tests and the acceptance conditions for equipment containing drain-holes or ventilation openings is the responsibility of the relevant Technical Committee.

In the absence of such specification the requirement of this standard shall apply.

The interpretation of test results is the responsibility of the relevant Technical Committee. In the absence of a specification the acceptance conditions of this standard shall at least apply.

11.4 Combination of test conditions for the first characteristic numeral

Designation with a first characteristic numeral implies that all test conditions are met for this numeral.

11.5 Empty enclosures

If the enclosure is tested without equipment inside, detailed requirements shall be indicated by the enclosure manufacturer in his instructions for the arrangement and spacing of hazardous parts or parts which might be affected by the penetration of foreign objects or water.

The manufacturer of the final assembly shall ensure that after the electrical equipment is enclosed the enclosure meets the declared degree of protection of the final product.

Table V — Test conditions for degrees of protection indicated by the first characteristic numeral

First characteristic numeral	Test for protection against	
	access to hazardous parts	solid foreign objects
0	No test required	No test required
1	The sphere of 50 mm Ø shall not fully penetrate and adequate clearance shall be kept	
2	The jointed test finger may penetrate up to its 80 mm length, but adequate clearance shall be kept	The sphere of 12,5 mm Ø shall not fully penetrate
3	The test rod of 2,5 mm Ø shall not penetrate and adequate clearance shall be kept	
4	The test wire of 1,0 mm Ø shall not penetrate and adequate clearance shall be kept	
5	The test wire of 1,0 mm Ø shall not penetrate and adequate clearance shall be kept	Dust-protected as specified in Table II
6	The test wire of 1,0 mm Ø shall not penetrate and adequate clearance shall be kept	Dust-tight as specified in Table II

In the case of the first characteristic numerals 1 and 2, “not fully penetrate” means that the full diameter of the sphere shall not pass through an opening of the enclosure.

12 Tests for protection against access to hazardous parts indicated by the first characteristic numeral

12.1 Access probes

Access probes to test the protection of persons against access to hazardous parts are given in Table VI.

12.2 Test conditions

The access probe is pushed against or (in case of the test for first characteristic numeral 2) inserted through any openings of the enclosure with the force specified in Table VI.

For tests on low-voltage equipment, a low-voltage supply (of not less than 40 V and not more than 50 V) in series with a suitable lamp should be connected between the probe and the hazardous parts inside the enclosure. Hazardous live parts covered only with varnish or paint, or protected by oxidation or by a similar process, are covered by a metal foil electrically connected to those parts which are normally live in operation.

The signal-circuit method should also be applied to the hazardous moving parts of high-voltage equipment.

Internal moving parts may be operated slowly, where this is possible.

12.3 Acceptance conditions

The protection is satisfactory if adequate clearance is kept between the access probe and hazardous parts.

For the test of first characteristic numeral 1, the access probe 50 mm diameter shall not completely pass through the opening.

For the test of first characteristic numeral 2, the jointed test finger may penetrate to its 80 mm length, but the stop face (Ø 50 mm × 20 mm) shall not pass through the opening. Starting from the straight position, both joints of the test finger shall be successively bent through an angle of up to 90° with respect to the axis of the adjoining section of the finger and shall be placed in every possible position.

See Annex A for further clarification.

Adequate clearance means:

12.3.1 For low-voltage equipment (rated voltages not exceeding 1 000 V a.c. and 1 500 V d.c.):

The access probe shall not touch hazardous live parts.

If adequate clearance is verified by a signal circuit between the probe and hazardous parts, the lamp shall not light.

NOTE The attention of relevant Technical Committees is drawn to the fact that in some types of electrical equipment the maximum voltage produced internally (r.m.s. value or d.c. value of the working voltage) is higher than the rated voltage of the equipment. This maximum voltage should be considered when the dielectric test voltage and the adequate clearance are determined.

Table VI — Access probes for the tests for protection of persons against access to hazardous parts

First numeral	Addit. letter	Access probe	Test force
1	A	<p>Sphere 50 mm diameter</p> <p>Approx. 100</p> <p>Ø 10</p> <p>Ø 4</p> <p>Handle Insulating material</p> <p>Guard Insulating material</p> <p>Rigid test sphere (Metal)</p> <p>Sphere 50^{+0.05}₀</p> <p>440/89</p>	50 N ± 10%
2	B	<p>Jointed test finger</p> <p>See Fig. 1 for full dimensions</p> <p>Insulating material</p> <p>Jointed test finger (Metal)</p> <p>Stop face (Ø 50 x 20)</p> <p>Ø 12</p> <p>80</p> <p>441/89</p>	10 N ± 10%
3	C	<p>Test rod 2.5 mm diameter, 100 mm long</p> <p>Approx. 100</p> <p>Ø 10</p> <p>Handle (Insulating material)</p> <p>Sphere 35 ± 0,2</p> <p>Stop face (Insulating material)</p> <p>Rigid test rod (Metal)</p> <p>Edges free from burrs</p> <p>100 ± 0,2</p> <p>Ø 2,5^{+0.05}₀</p> <p>442/89</p>	3 N ± 10%
4, 5, 6	D	<p>Test wire 1.0 mm diameter, 100 mm long</p> <p>Approx. 100</p> <p>Ø 10</p> <p>Handle (Insulating material)</p> <p>Sphere 35 ± 0,2</p> <p>Stop face (Insulating material)</p> <p>Rigid test wire (Metal)</p> <p>Edges free from burrs</p> <p>100 ± 0,2</p> <p>Ø 1^{+0.05}₀</p> <p>443/89</p>	1 N ± 10%

Table VII — Test means for the tests for protection against solid foreign objects

First characteristic numeral	Test means (object probes and dust chamber)	Test force	Test conditions
0	No test required	—	
1	Rigid sphere without handle or guard 50 ^{+0,05} ₀ mm diameter	50 N ± 10%	13.2
2	Rigid sphere without handle or guard 12,5 ^{+0,2} ₀ mm diameter	30 N ± 10%	13.2
3	Rigid steel rod 2,5 ^{+0,05} ₀ mm diameter with edges free from burrs	3 N ± 10%	13.2
4	Rigid steel wire 1,0 ^{+0,05} ₀ mm diameter with edges free from burrs	1 N ± 10%	13.2
5	Dust chamber Figure 2, with or without underpressure	—	13.4 + 13.5
6	Dust chamber Figure 2, with underpressure	—	13.4 + 13.6

12.3.2 For high-voltage equipment (rated voltages exceeding 1 000 V a.c. and 1 500 V d.c.):

When the access probe is placed in the most unfavourable position(s), the equipment shall be capable of withstanding the dielectric tests as specified in the relevant product standard applicable to the equipment.

Verification may be made either by dielectric test or by inspection of the specified clearance dimension in air which would ensure that the tests would be satisfactory under the most unfavourable electric field configuration (see IEC 71-2).

In the case where an enclosure includes sections at different voltage levels the appropriate acceptance conditions for adequate clearance shall be applied for each section.

NOTE The attention of relevant Technical Committees is drawn to the fact that in some types of electrical equipment the maximum voltage produced internally (r.m.s. value or d.c. value of the working voltage) is higher than the rated voltage of the equipment. This maximum voltage should be considered when the dielectric test voltage and the adequate clearance are determined.

12.3.3 For equipment with hazardous mechanical parts:

The access probe shall not touch hazardous mechanical parts.

If adequate clearance is verified by a signal circuit between the probe and hazardous parts, the lamp shall not light.

13 Tests for protection against solid foreign objects indicated by the first characteristic numeral

13.1 Test means

Test means and the main test conditions are given in Table VII.

13.2 Test conditions for first characteristic numerals 1, 2, 3, 4

The object probe is pushed against any openings of the enclosure with the force specified in Table VII.

13.3 Acceptance conditions for first characteristic numerals 1, 2, 3, 4

The protection is satisfactory if the full diameter of the probe specified in Table VII does not pass through any opening.

NOTE For the first characteristic numerals 3 and 4 the probes specified in Table VII are intended to simulate foreign objects which may be spherical. Where an enclosure has an indirect or tortuous entry path and there is any doubt about ingress of a spherical object capable of motion, it may be necessary to examine drawings or to provide special access for the object probe to be applied with the specified force to the opening(s) where ingress has to be checked.

13.4 Dust test for first characteristic numerals 5 and 6

The test is made using a dust chamber incorporating the basic principles shown in Figure 2 whereby the powder circulation pump may be replaced by other means suitable to maintain the talcum powder in suspension in a closed test chamber. The talcum powder used shall be able to pass through a square-meshed sieve the nominal wire diameter of which is 50 μm and the nominal width of a gap between wires 75 μm . The amount of talcum powder to be used is 2 kg per cubic metre of the test chamber volume. It shall not have been used for more than 20 tests.

NOTE Health and safety regulations should be observed in selecting the type of talcum powder and its use.

Enclosures are of necessity in one of two categories:

Category 1: Enclosures where the normal working cycle of the equipment causes reductions in air pressure within the enclosure below that of the surrounding air, e.g., due to thermal cycling effects.

Category 2: Enclosures where no pressure difference relative to the surrounding air is present.

Category 1 enclosures:

The enclosure under test is supported inside the test chamber and the pressure inside the enclosure is maintained below the surrounding atmospheric pressure by a vacuum pump. The suction connection shall be made to a hole specially provided for this test. If not otherwise specified in the relevant product standard, this hole shall be in the vicinity of the vulnerable parts.

If it is impracticable to make a special hole, the suction connection shall be made to the cable inlet hole. If there are other holes (e.g., more cable inlet holes or drain-holes) these shall be treated as intended for normal use on site.

The object of the test is to draw into the enclosure, by means of depression, a volume of air 80 times the volume of the sample enclosure tested without exceeding the extraction rate of 60 volumes per hour. In no event shall the depression exceed 2 kPa (20 mbar) on the manometer shown in Figure 2.

If an extraction rate of 40 to 60 volumes per hour is obtained the duration of the test is 2 h.

If, with a maximum depression of 2 kPa (20 mbar), the extraction rate is less than 40 volumes per hour, the test is continued until 80 volumes have been drawn through, or a period of 8 h has elapsed.

Category 2 enclosures:

The enclosure under test is supported in its normal operating position inside the test chamber, but is not connected to a vacuum pump. Any drain-hole normally open shall be left open for the duration of the test. The test shall be continued for a period of 8 h.

Category 1 and category 2 enclosures:

If it is impracticable to test the complete enclosure in the test chamber, one of the following procedures shall be applied:

- testing of individually enclosed sections of the enclosure;
- testing of representative parts of the enclosure, comprising components such as doors, ventilation openings, joints, shaft seals, etc., in position during test;
- testing of a smaller enclosure having the same full-scale design details.

In the last two cases, the volume of air to be drawn through the enclosure under test shall be the same as for the whole enclosure in full scale.

13.5 Special conditions for first characteristic numeral 5

13.5.1 Test conditions for first characteristic numeral 5

The enclosure shall be deemed category 1 unless the relevant product standard for the equipment specifies that the enclosure is category 2.

13.5.2 Acceptance conditions for first characteristic numeral 5

The protection is satisfactory if, on inspection, talcum powder has not accumulated in a quantity or location such that, as with any other kind of dust, it could interfere with the correct operation of the equipment or impair safety. Except for special cases to be clearly specified in the relevant product standard, no dust shall deposit where it could lead to tracking along the creepage distances.

13.6 Special conditions for first characteristic numeral 6

13.6.1 Test conditions for first characteristic numeral 6

The enclosure shall be deemed category 1, whether reductions in pressure below the atmospheric pressure are present or not.

13.6.2 Acceptance conditions for first characteristic numeral 6

The protection is satisfactory if no deposit of dust is observable inside the enclosure at the end of the test.

Table VIII — Test means and main test conditions for the tests for protection against water

Second characteristic numeral	Test means	Water flow rate	Duration of test	Test conditions, see
0	No test required	—	—	—
1	Drip box Figure 3 Enclosure on turntable	$1 \begin{smallmatrix} +0,5 \\ 0 \end{smallmatrix}$ mm/min	10 min	14.2.1
2	Drip box Figure 3 Enclosure in 4 fixed positions of 15° tilt	$3 \begin{smallmatrix} +0,5 \\ 0 \end{smallmatrix}$ mm/min	20 min for each position of tilt	14.2.2
3	Oscillating tube Figure 4 Spray ± 60° from vertical, distance max. 200 mm or Spray nozzle Figure 5 Spray ± 60° from vertical	0,07 l/min ± 5% per hole, multiplied by number of holes 10 l/min ± 5%	10 min 1 min/m ² at least 5 min	14.2.3 a) 14.2.3 b)
4	As for numeral 3 Spray ± 180° from vertical	As for numeral 3		14.2.4
5	Water jet hose nozzle Figure 6 Nozzle 6,3 mm diameter, distance 2,5 m to 3 m	12,5 l/min ± 5%	1 min/m ² at least 3 min	14.2.5
6	Water jet hose nozzle Figure 6 Nozzle 12,5 mm diameter, distance 2,5 m to 3 m	100 l/min ± 5%	1 min/m ² at least 3 min	14.2.6
7	Immersion tank Water-level on enclosure: 0,15 m above top 1 m above bottom	—	30 min	14.2.7
8	Immersion tank Water-level: by agreement	—	by agreement	14.2.8
A2 9	Fan jet nozzle Figure 7 Test of small enclosure on turntable Figure 12 Turntable speed (5 ± 1) r/min Spray at 0°, 30°, 60°, 90° Or Test of large enclosures as per intended use Spray from all practical directions Distance (175 ± 25) mm	(15 ± 1) l/min	30 s per position 1 min/m ² at least 3 min	14.2.9 a) 14.2.9 b)

14 Tests for protection against water indicated by the second characteristic numeral

14.1 Test means

The test means and the main test conditions are given in Table VIII.

14.2 Test conditions

Test means and main test conditions are given in Table VIII.

A2 Details concerning compliance of degrees of protection – in particular for second characteristic numerals 5/6/9 (water jets) and numerals 7/8 (immersion) – are given in Clause 6. **A2**

The tests are conducted with fresh water.

During the tests for IPX1 to IPX6 the water temperature should not differ by more than 5 K from the temperature of the specimen under test. If the water temperature is more than 5 K below the temperature of the specimen a pressure balance shall be provided for the enclosure. A_2 For IPX7 and IPX9 details of the water temperature are given in 14.2.7 and 14.2.9 respectively. A_2

During the test, the moisture contained inside the enclosure may partly condense. The dew which may thus deposit shall not be mistaken for an ingress of water.

For the purpose of the tests, the surface area of the enclosure is calculated with a tolerance of 10 %.

Adequate safety precautions should be taken when testing the equipment in the energized condition.

14.2.1 Test for second characteristic numeral 1 with the drip box

The test is made with a device which produces a uniform flow of water drops over the whole area of the enclosure.

An example of such a device is shown in Figure 3 a).

The turntable on which the enclosure is placed has a rotation speed of 1 r/min and the eccentricity (distance between turntable axis and specimen axis) is approximately 100 mm.

The enclosure under test is placed in its normal operating position under the drip box, the base of which is larger than that of the enclosure. Except for enclosures designed for wall or ceiling mounting, the support for the enclosure under test should be smaller than the base of the enclosure.

An enclosure normally fixed to a wall or ceiling is fixed in its normal position of use to a wooden board having dimensions which are equal to those of that surface of the enclosure which is in contact with the wall or ceiling when the enclosure is mounted as in normal use.

The duration of test is 10 min.

NOTE When the base of the drip box is smaller than that of the enclosure under test, the latter may be divided into several sections, the area of each section being large enough to be covered by the dripping water. The test is continued until the whole area of the enclosure has been sprinkled for the specified time.

14.2.2 Test for second characteristic numeral 2 with the drip box

The dripping device is the same as specified in 14.2.1 adjusted to provide the water flow rate specified in Table VIII.

The table on which the enclosure is placed does not turn as in the case of the test for the second characteristic numeral 1.

The enclosure is tested for 2,5 min in each of four fixed positions of tilt. These positions are 15° on either side of the vertical in two mutually perpendicular planes (see Figure 3 b)).

The total duration of the test is 10 min.

14.2.3 Test for second characteristic numeral 3 with oscillating tube or spray nozzle

The test is made using one of the two test devices described in Figure 4 and in Figure 5 in accordance with the relevant product standard.

a) Conditions when using the test device as in Figure 4 (oscillating tube):

The total flow rate is adjusted as specified in Table IX and is measured with a flow meter.

The oscillating tube is provided with spray holes over an arc of 60° either side of the centre point.

The support is not perforated.

The enclosure to be tested is placed at the centre point of the semicircle. The tube is caused to oscillate through an angle of 120°, 60° on either side of the vertical, the time for one complete oscillation ($2 \times 120^\circ$) being about 4 s and the test duration being 5 min.

The enclosure is then turned through an horizontal angle of 90° and the test is continued for a further 5 min.

The maximum acceptable radius of the oscillating tube is 1 600 mm.

If for certain types of apparatus it is not possible to wet all parts of the enclosure under test, the support of the enclosure may be moved up or down. The hand-held test device as in Figure 5 (spray nozzle) should be used as a preference in such cases.

b) Conditions when using the test device as in Figure 5 (spray nozzle):

The counterbalanced shield is in place for this test.

The water pressure is adjusted to give the specified delivery rate. The pressure to achieve this delivery rate will be in the range of 50 kPa to 150 kPa. It should be kept constant during the test.

The test duration is 1 min/m² of the calculated surface area of the enclosure (excluding any mounting surface), with a minimum duration of 5 min.

14.2.4 Test for second characteristic numeral 4 with oscillating tube or spray nozzle

The test is made using one of the two test devices described in Figure 4 and in Figure 5 in accordance with the relevant product standard.

a) Conditions when using the test device as in Figure 4 (oscillating tube):

The oscillating tube has spray holes over the whole 180° of the semicircle. The total flow rate is adjusted as specified in Table IX and is measured with a flow meter.

The tube is caused to oscillate through an angle of almost 360°, 180° on either side of the vertical, the time for one complete oscillation ($2 \times 360^\circ$) being about 12 s.

The duration of the test is 10 min.

If not specified otherwise in the relevant product standard, the support for the enclosure under test is perforated so as to avoid acting as a baffle and the enclosure is sprayed from every direction by oscillating the tube to the limit of its travel in each direction.

b) Conditions when using the test device as in Figure 5 (spray nozzle):

The counterbalanced shield is removed from the spray nozzle and the enclosure is sprayed from all practicable directions.

The rate of water flow and the spraying time per unit area are as specified in 14.2.3.

14.2.5 Test for second characteristic numeral 5 with the 6,3 mm nozzle

The test is made by spraying the enclosure from all practicable directions with a stream of water from a standard test nozzle as shown in Figure 6.

The conditions to be observed are as follows:

- internal diameter of the nozzle: 6,3 mm;
- delivery rate: 12,5 l/min ± 5 %;
- water pressure: to be adjusted to achieve the specified delivery rate;
- core of the substantial stream: circle of approximately 40 mm diameter at 2,5 m distance from nozzle;
- test duration per square metre of enclosure surface area likely to be sprayed: 1 min;
- minimum test duration: 3 min;
- distance from nozzle to enclosure surface: between 2,5 m and 3 m.

14.2.6 Test for second characteristic numeral 6 with the 12,5 mm nozzle

The test is made by spraying the enclosure from all practicable directions with a stream of water from a standard test nozzle as shown in Figure 6.

The conditions to be observed are as follows:

- internal diameter of the nozzle: 12,5 mm;

- delivery rate: 100 l/min ± 5 %;
- water pressure: to be adjusted to achieve the specified delivery rate;
- core of the substantial stream: circle of approximately 120 mm diameter at 2,5 m distance from nozzle;
- test duration per square metre of enclosure surface area likely to be sprayed: 1 min;
- minimum test duration: 3 min;
- distance from nozzle to enclosure surface: between 2,5 m and 3 m.

14.2.7 Test for second characteristic numeral 7: temporary immersion between 0,15 m and 1 m

The test is made by completely immersing the enclosure in water in its service position as specified by the manufacturer so that the following conditions are satisfied:

- a) the lowest point of enclosures with a height less than 850 mm is located 1 000 mm below the surface of the water;
- b) the highest point of enclosures with a height equal to or greater than 850 mm is located 150 mm below the surface of the water;
- c) the duration of the test is 30 min;
- d) the water temperature does not differ from that of the equipment by more than 5 K. However, a modified requirement may be specified in the relevant product standard if the tests are to be made when the equipment is energized and/or its parts in motion.

14.2.8 Test for second characteristic numeral 8: continuous immersion subject to agreement

Unless there is a relevant product standard, the test conditions are subject to agreement between manufacturer and user, but they shall be more severe than those prescribed in 14.2.7 and they shall take account of the condition that the enclosure will be continuously immersed in actual use.

**Table IX — Total water flow rate q_v under IPX3 and IPX4 test conditions
Mean flow rate per hole $q_{v1} = 0,07$ l/min**

Tube radius R mm	Degree IPX3		Degree IPX4	
	Number of open holes N^a	Total water flow q_v l/min	Number of open holes N^a	Total water flow q_v l/min
200	8	0,56	12	0,84
400	16	1,1	25	1,8
600	25	1,8	37	2,6
800	33	2,3	50	3,5
1 000	41	2,9	62	4,3
1 200	50	3,5	75	5,3
1 400	58	4,1	87	6,1
1 600	67	4,7	100	7,0

^a Depending on the actual arrangement of the hole centres at the specified distance, the number of open holes N may be increased by 1.

A₂ 14.2.9 *Test for second characteristic numeral 9 by high pressure and temperature water jetting*

The test is made by spraying the enclosure with a stream of water from a standard test nozzle as shown in Figures 7, 8 and 9.

The set-up for measuring the impact force of the water jet is given in Figure 10.

The distribution force shall be verified at upper and lower limits of distance tolerance range (see Figure 11).

During the test a) or b) of the enclosure, the water temperature shall be $(80 \pm 5) ^\circ\text{C}$.

a) For small enclosures (largest dimension less than 250 mm), the enclosure shall be mounted on the test device shown in Figure 12.

- turntable speed: 5 r/min ± 1 r/min
- spray positions: 0°, 30°, 60°, 90°

The test duration is 30 s per position.

b) For large enclosures (largest dimension greater than or equal to 250 mm), the enclosure shall be mounted as per intended use. The entire exposed surface area of the enclosure shall be subjected to the spray at some point during the test procedure.

- spray positions: the enclosure shall be sprayed from all practical directions covering the entire surface area and the spray shall be, as far as possible, perpendicular to the sprayed surface.
- distance between nozzle and sample under test shall be 175 ± 25 mm.

The test duration is 1 min/m² of the calculated surface area of the enclosure (excluding any mounting surface), with a minimum duration of 3 min. **A₂**

14.3 Acceptance conditions

A₂ After testing in accordance with the appropriate requirements of 14.2.1 to 14.2.9, the enclosure shall be inspected for ingress of water. **A₂**

It is the responsibility of the relevant Technical Committee to specify the amount of water which may be allowed to enter the enclosure and the details of a dielectric strength test, if any.

In general, if any water has entered, it shall not:

- be sufficient to interfere with the correct operation of the equipment or impair safety;
- deposit on insulation parts where it could lead to tracking along the creepage distances;
- reach live parts or windings not designed to operate when wet;
- accumulate near the cable end or enter the cable if any.

If the enclosure is provided with drain-holes, it should be proved by inspection that any water which enters does not accumulate and that it drains away without doing any harm to the equipment.

For enclosures without drain-holes, the relevant product standard shall specify the acceptance conditions if water can accumulate on reach live parts.

15 Tests for protection against access to hazardous parts indicated by the additional letter**15.1 Access probes**

Access probes to verify the protection of persons against access to hazardous parts are given in Table VI.

15.2 Test conditions

The access probe is pushed against any openings of the enclosure with the force specified in Table VI. If it partly or fully penetrates, it is placed in every possible position, but in no case shall the stop face fully penetrate through the opening.

Internal barriers are considered part of the enclosure as defined in 3.1.

For tests on low-voltage equipment, a low-voltage supply (of not less than 40 V and not more than 50 V) in series with a suitable lamp should be connected between the probe and the hazardous parts inside the enclosure. Hazardous live parts covered only with varnish or paint, or protected by oxidation or by a similar process, are covered by a metal foil electrically connected to those parts which are normally live in operation.

The signal-circuit method should also be applied to the hazardous moving parts of high-voltage equipment.

Internal moving parts may be operated slowly, where this is possible.

15.3 Acceptance conditions

The protection is satisfactory if adequate clearance is kept between the access probe and hazardous parts.

In the case of the test for the additional letter B, the jointed test finger may penetrate to its 80 mm length, but the stop face ($\varnothing 50$ mm × 20 mm) shall not pass through the opening. Starting from the straight position, both joints of the test finger shall be successively bent through an angle of up to 90° with respect to the axis of the adjoining section of the finger and shall be placed in every possible position.

In case of the tests for the additional letters C and D, the access probe may penetrate to its full length, but the stop face shall not fully penetrate through the opening. See Annex A for further clarification.

Conditions for verification of adequate clearance are identical with those given in 12.3.1, 12.3.2 and 12.3.3.

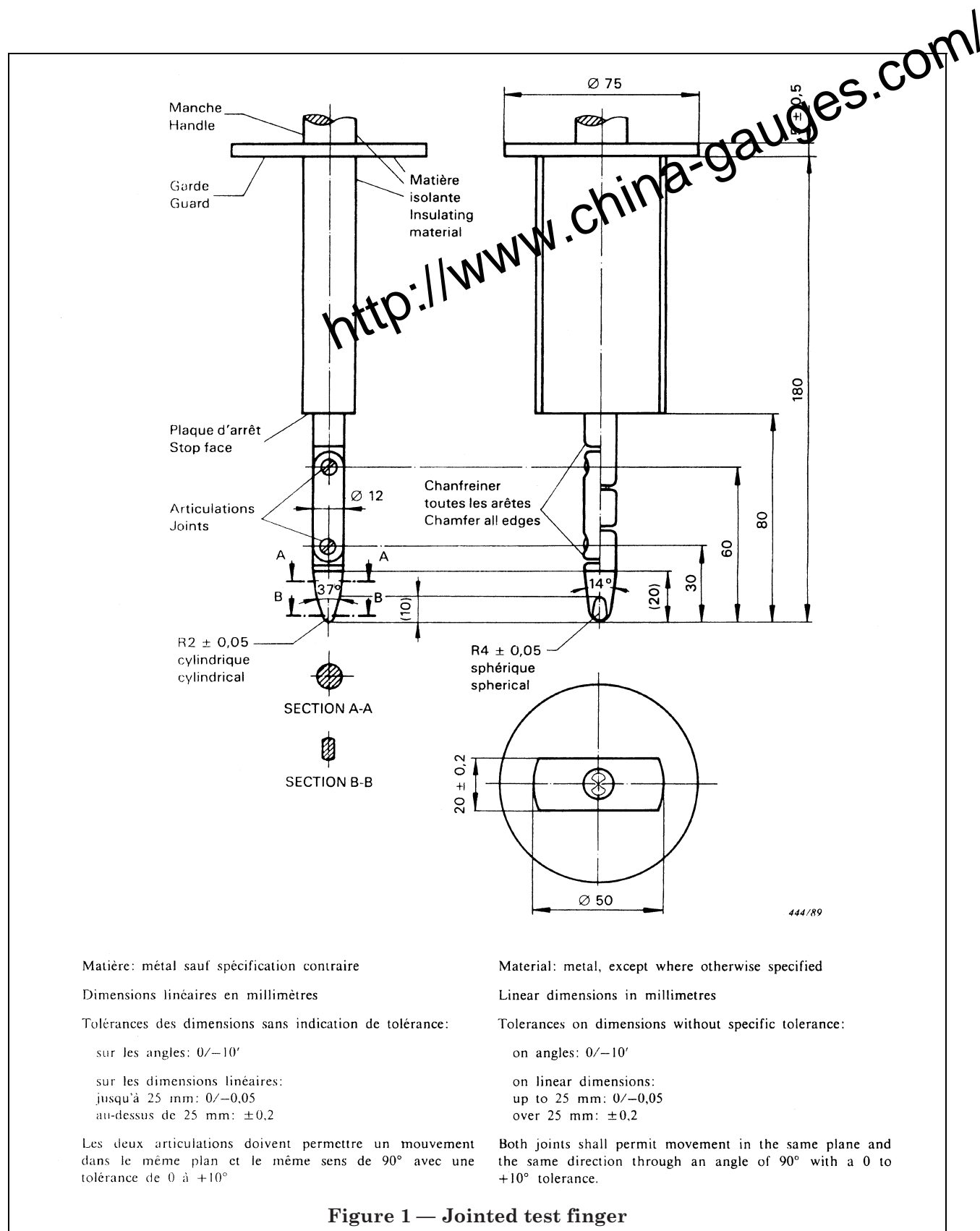

Matière: métal sauf spécification contraire

Dimensions linéaires en millimètres

Tolérances des dimensions sans indication de tolérance:

sur les angles: 0/-10°

sur les dimensions linéaires:
jusqu'à 25 mm: 0/-0,05
au-dessus de 25 mm: ±0,2

Les deux articulations doivent permettre un mouvement dans le même plan et le même sens de 90° avec une tolérance de 0 à +10°

Material: metal, except where otherwise specified

Linear dimensions in millimetres

Tolerances on dimensions without specific tolerance:

on angles: 0/-10°

on linear dimensions:
up to 25 mm: 0/-0,05
over 25 mm: ±0,2

Both joints shall permit movement in the same plane and the same direction through an angle of 90° with a 0 to +10° tolerance.

Figure 1 — Jointed test finger

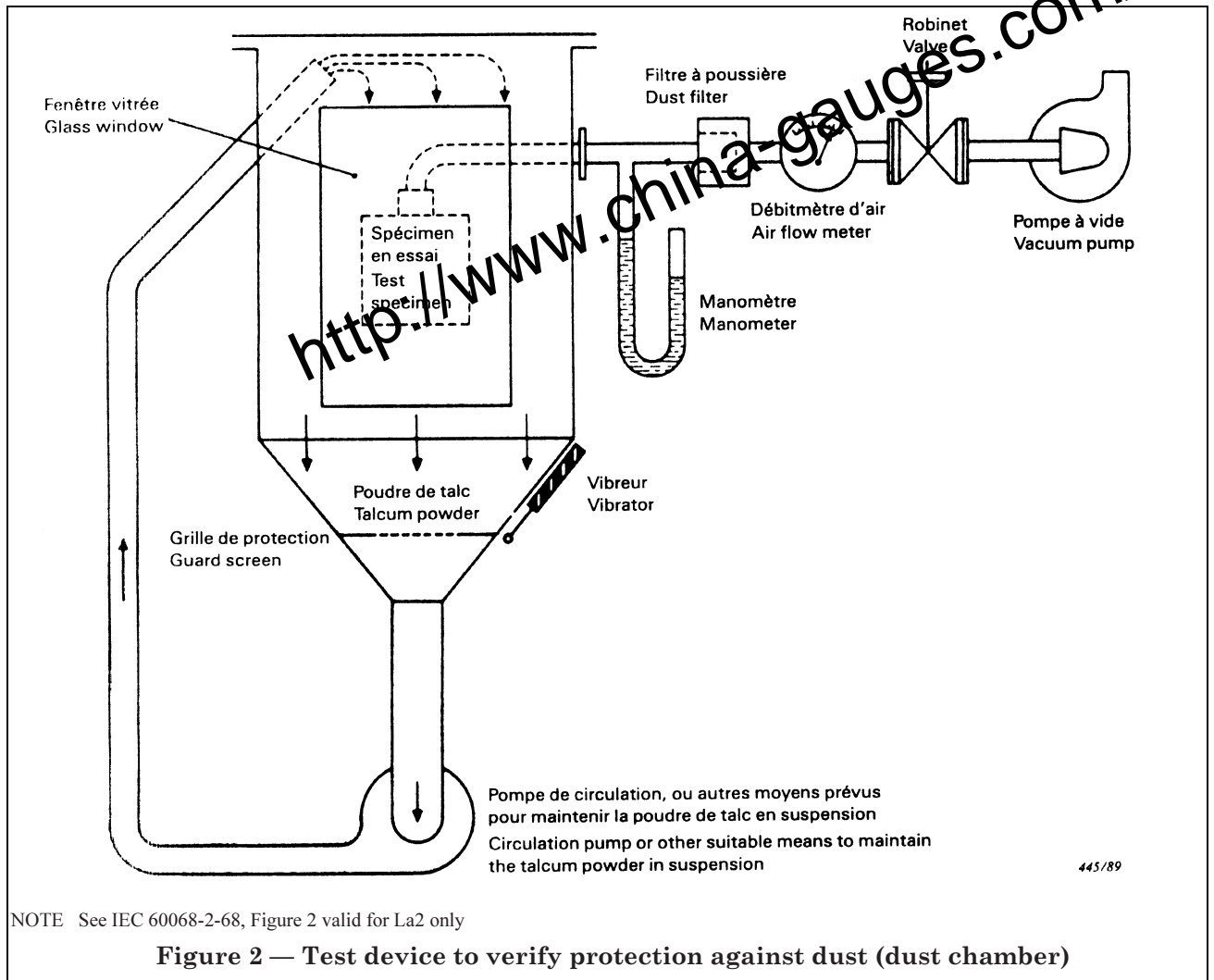

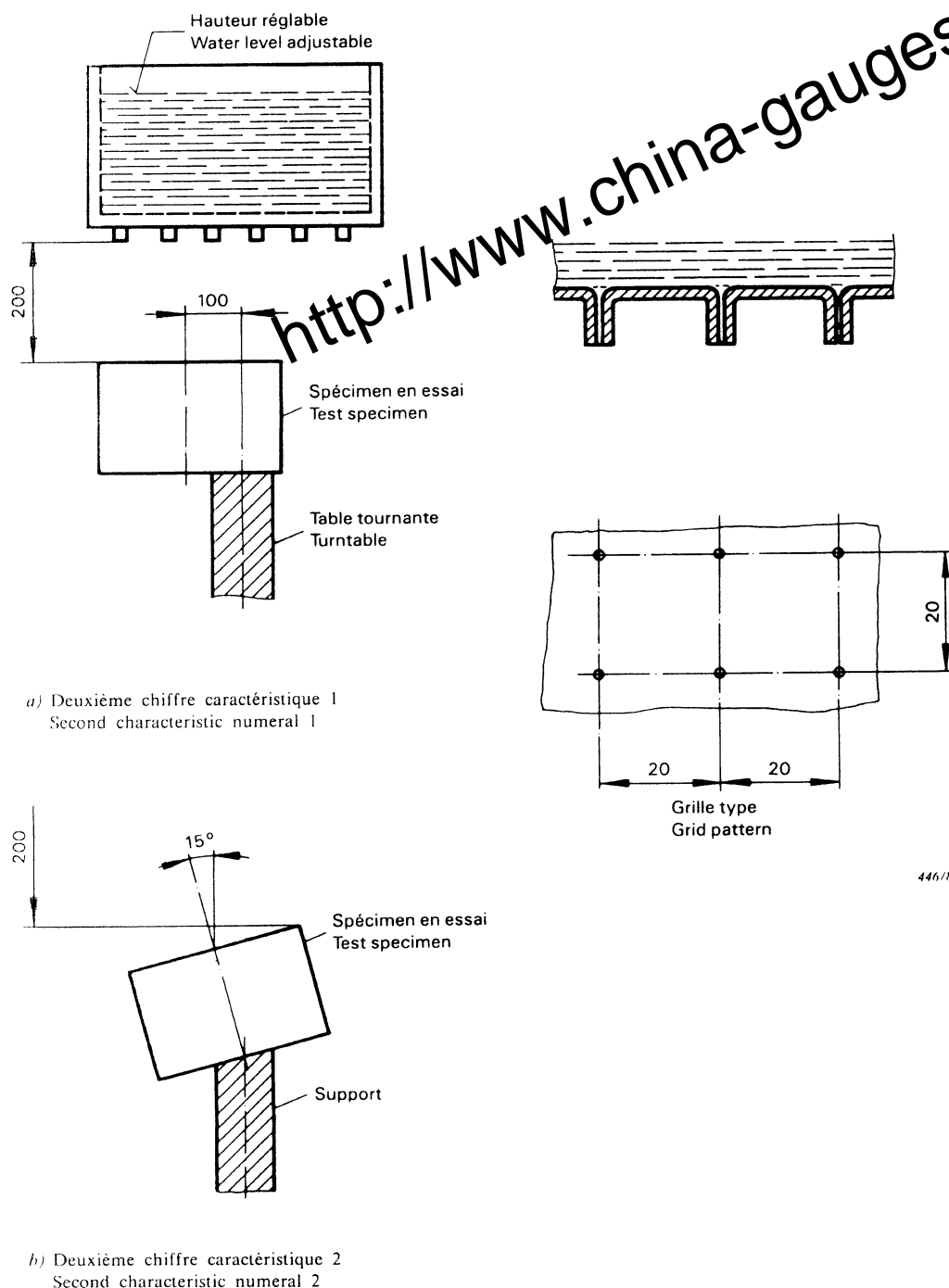

Dimensions en millimètres

Dimensions in millimetres

Figure 3 — Test device to verify protection against vertically falling water drops (drip box)

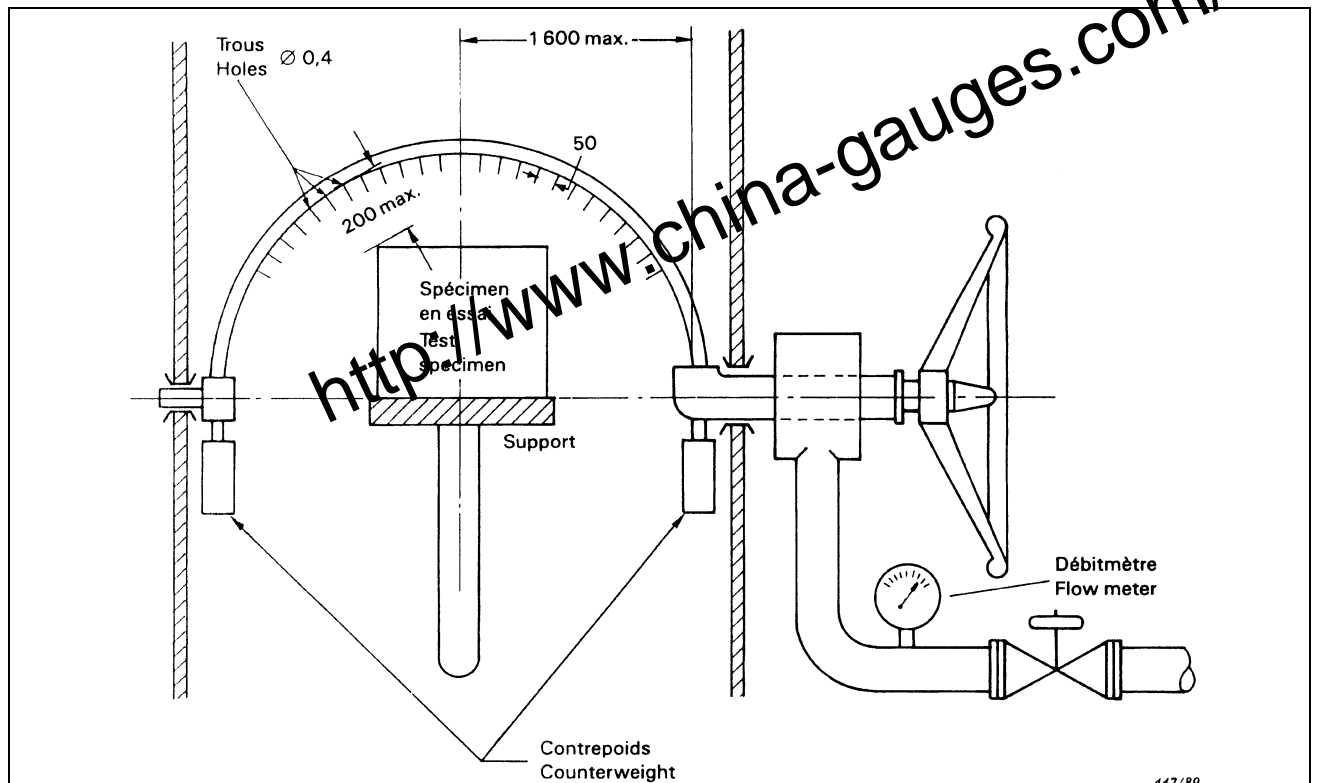

Dimensions en millimètres

Dimensions in millimetres

Figure 4 — Test device to verify protection against spraying and splashing water; second characteristic numerals 3 and 4 (oscillating tube)

NOTE La répartition des trous est représentée comme pour le deuxième chiffre caractéristique 3 (voir 14.2.3 a))
The range of holes is shown as for second characteristic numeral 3 (see 14.2.3 a))

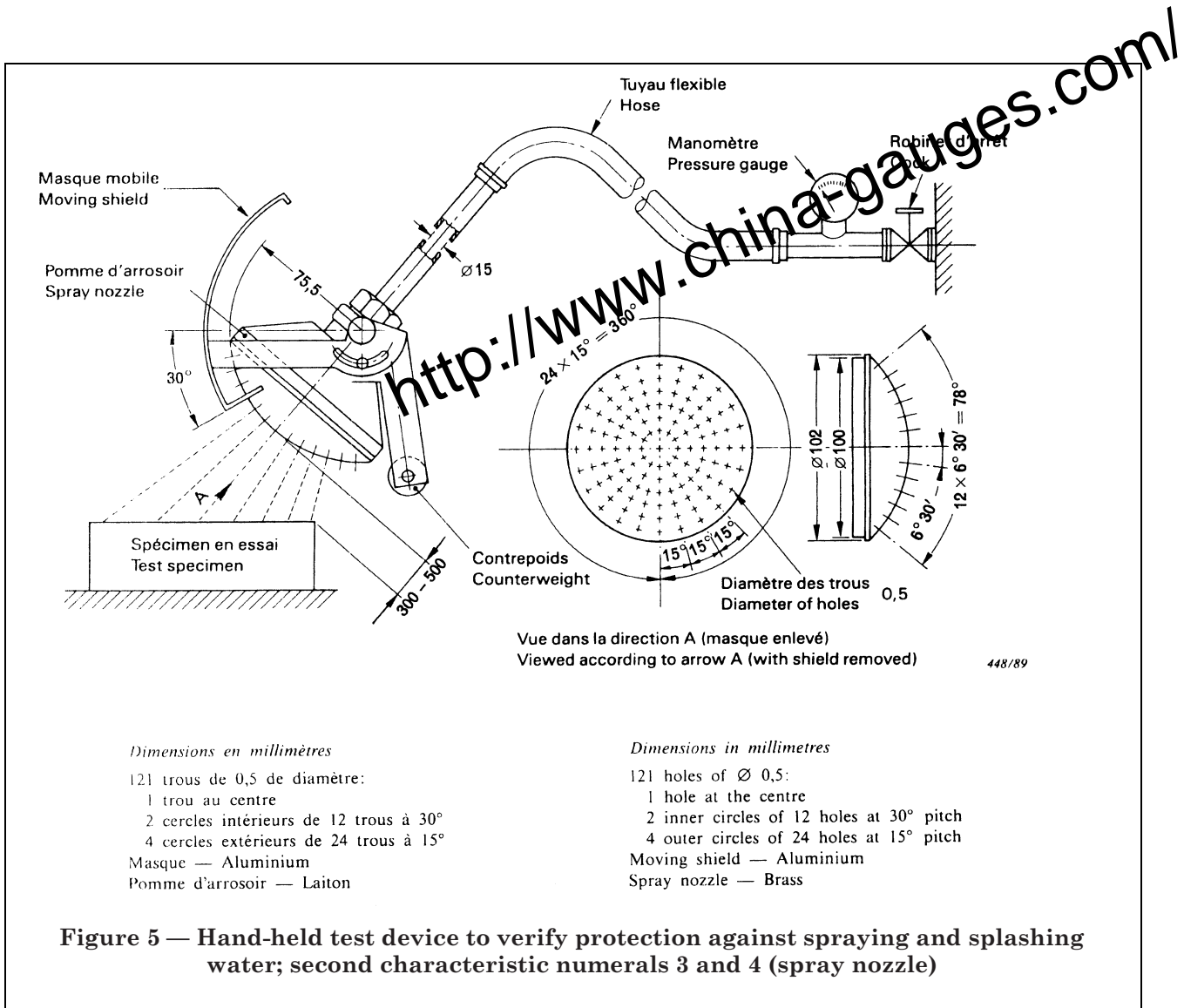
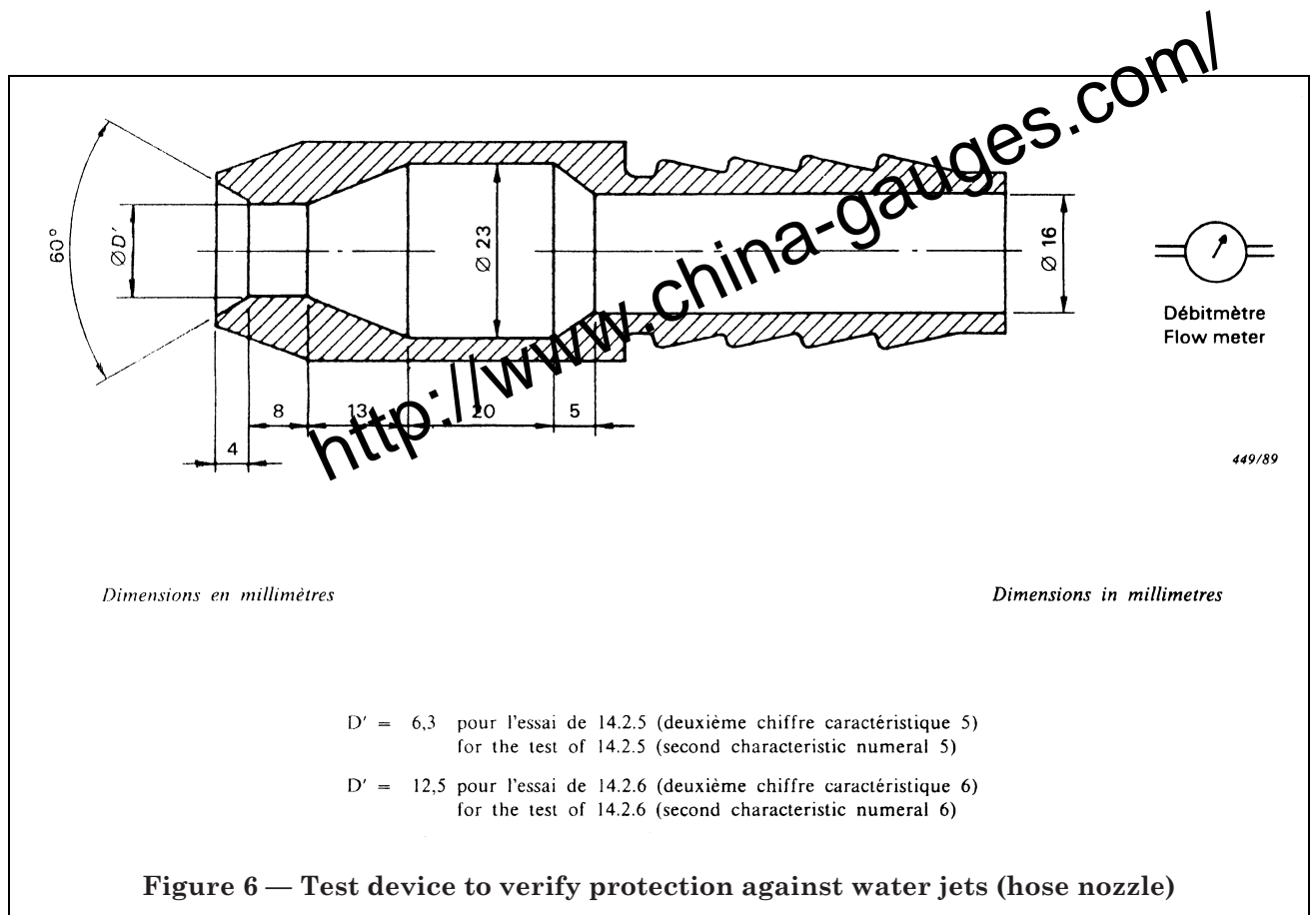
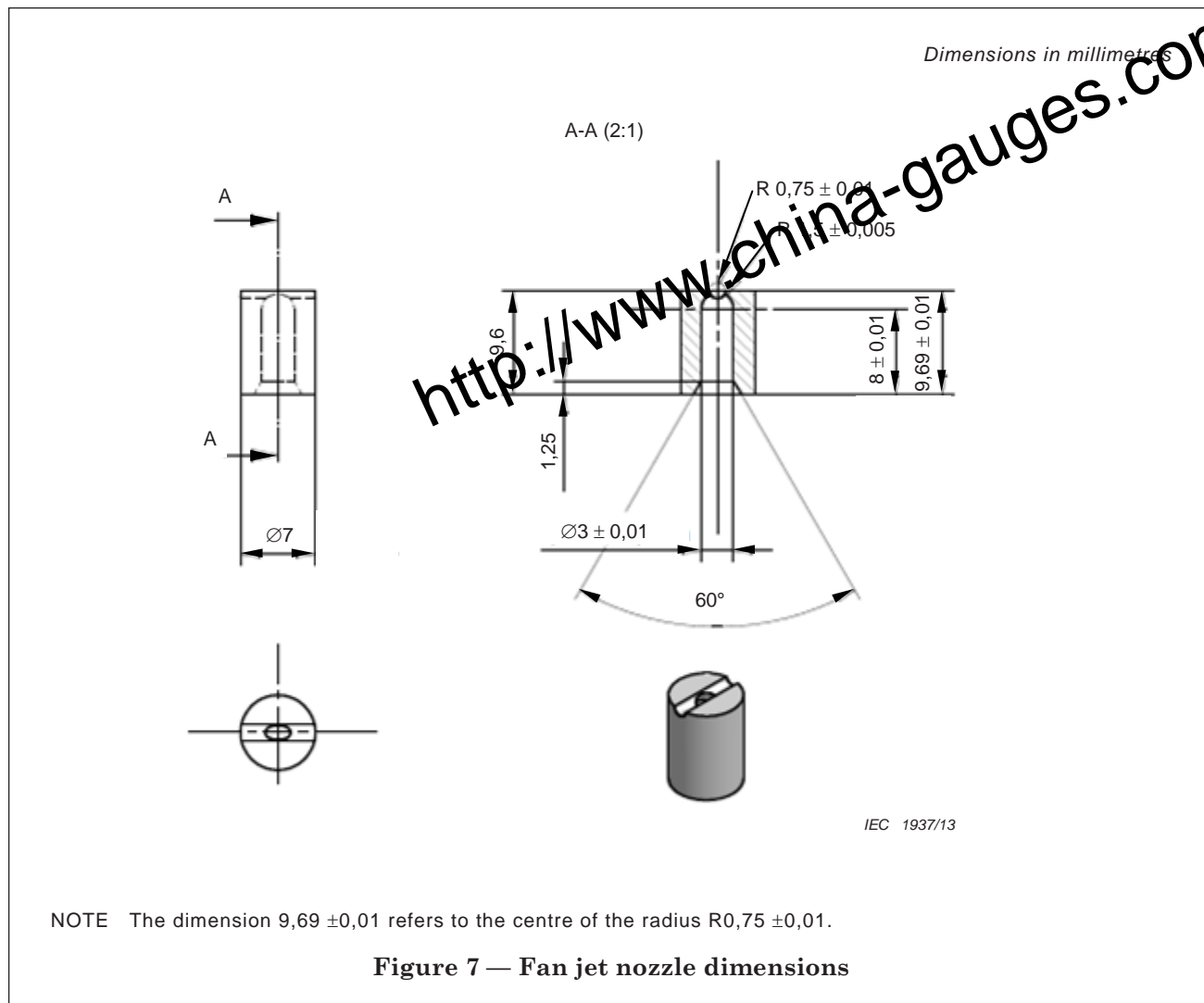

Figure 5 — Hand-held test device to verify protection against spraying and splashing water; second characteristic numerals 3 and 4 (spray nozzle)



A2



A2

A2

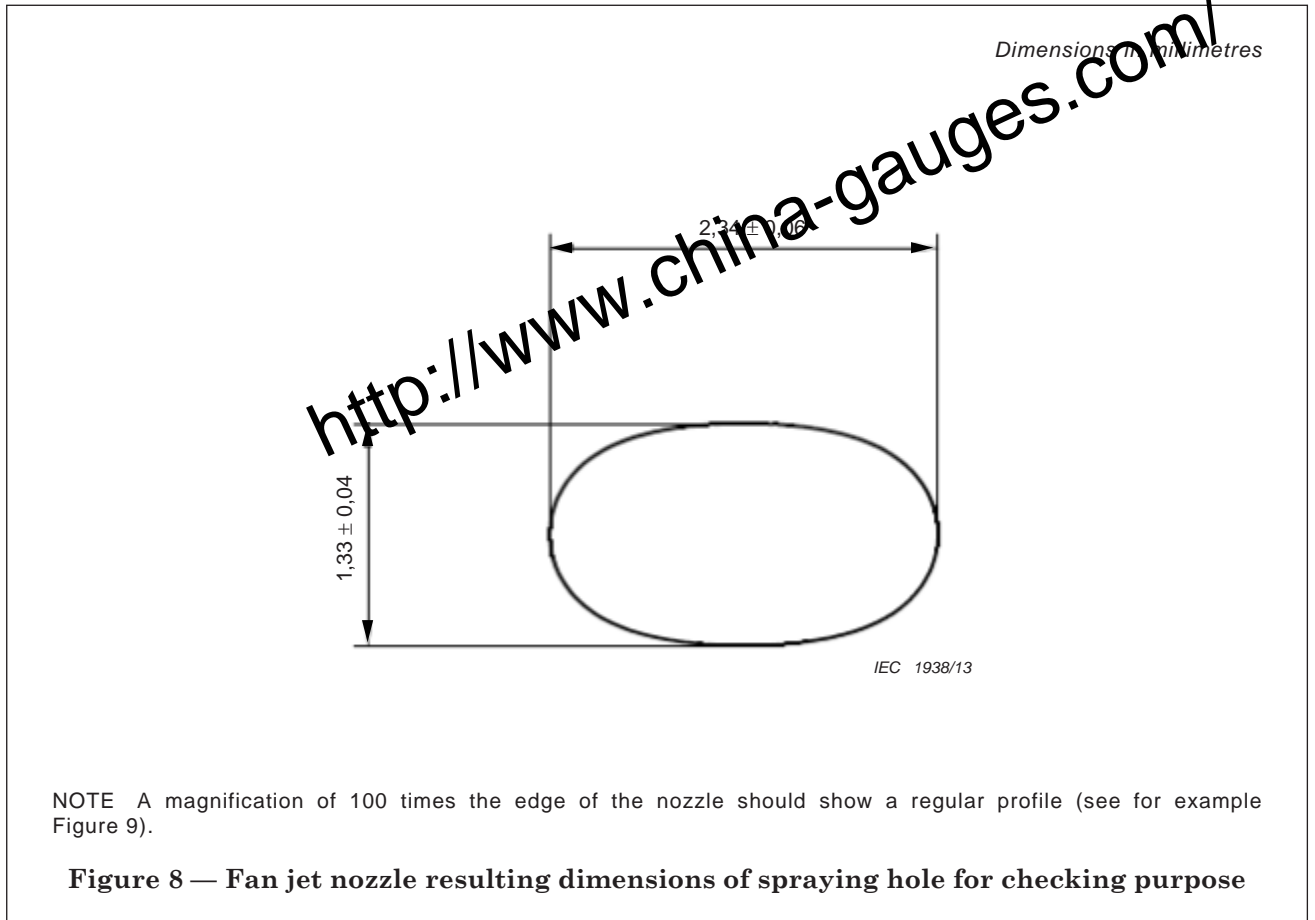

A2

A2

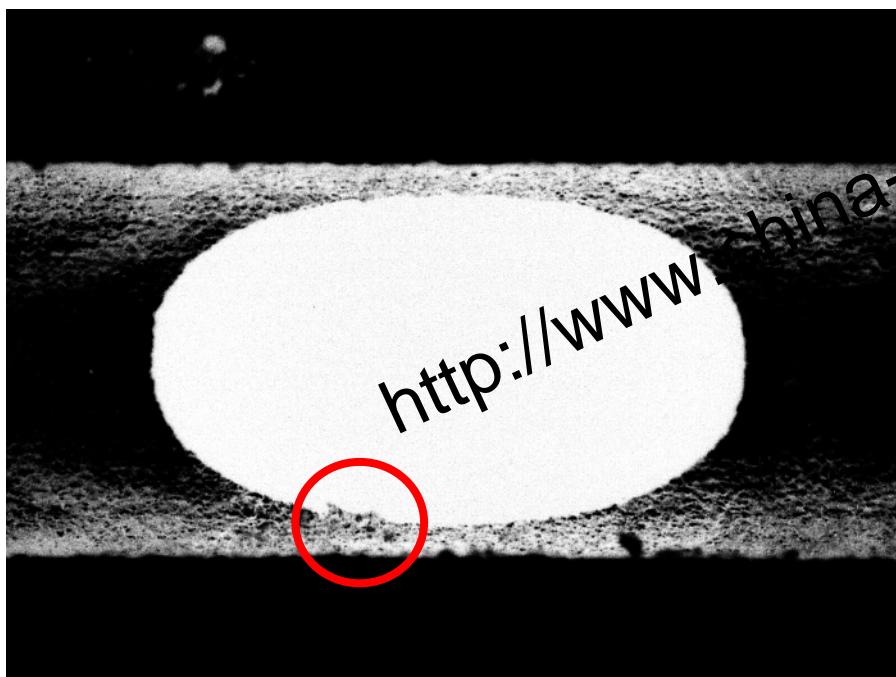

Bad surface finish

IEC 1939/13

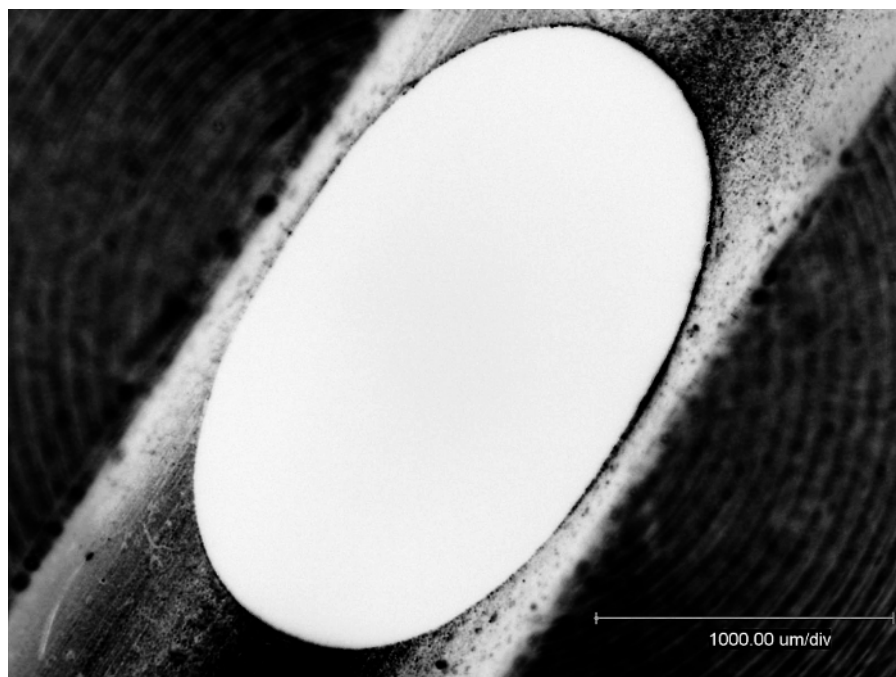

Good surface finish

IEC 1940/13

Figure 9 — Example of different quality achievements of the surface finish of the fan jet nozzle

A2

A2

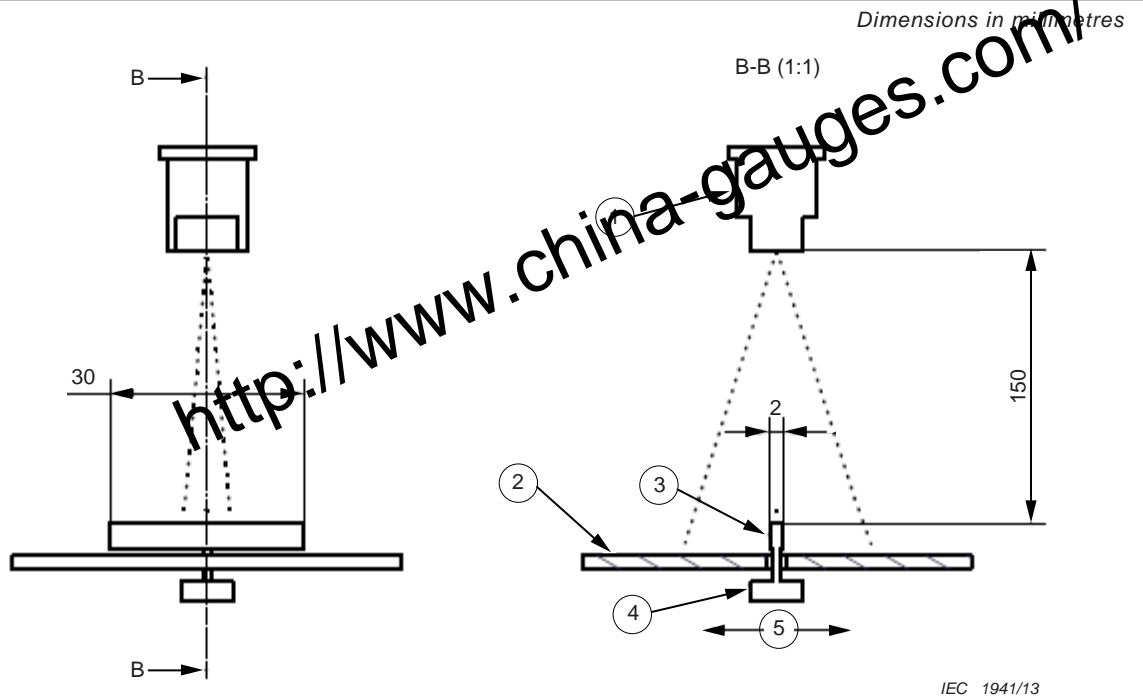

Key

- 1 fan jet nozzle:
adjustment of the flow – rate between (15 ± 1) l/min to reach a distribution impact force of 0,9 – 1,2 N.
Water temperature during verification (20 ± 5) °C.
- 2 cover plate
- 3 impact plate 2 mm \times 30 mm
- 4 force sensor
- 5 distribution forces directions (see also Figure 11)

Figure 10 — Set-up for measuring the impact force of the water jet for determining the protection against high pressure and temperature water jet, degree of protection against ingress of water IP X9

A2

A2

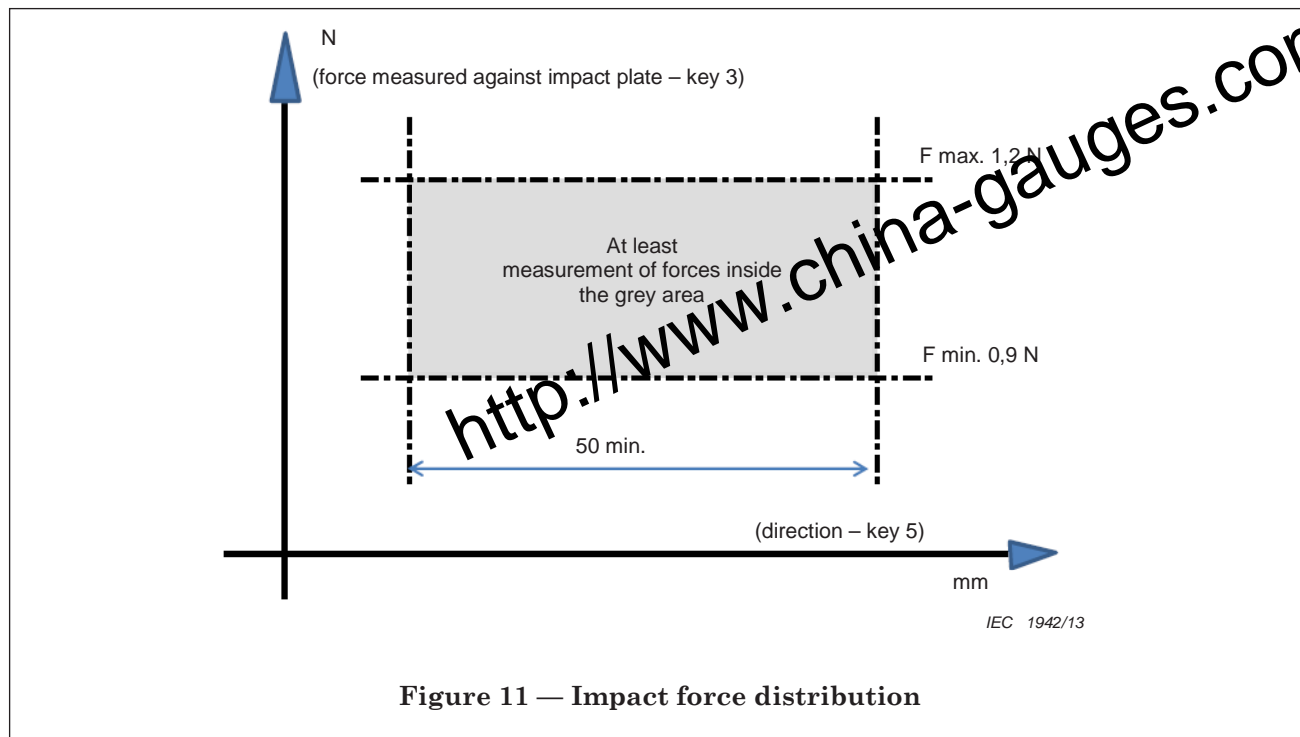

A2

A2

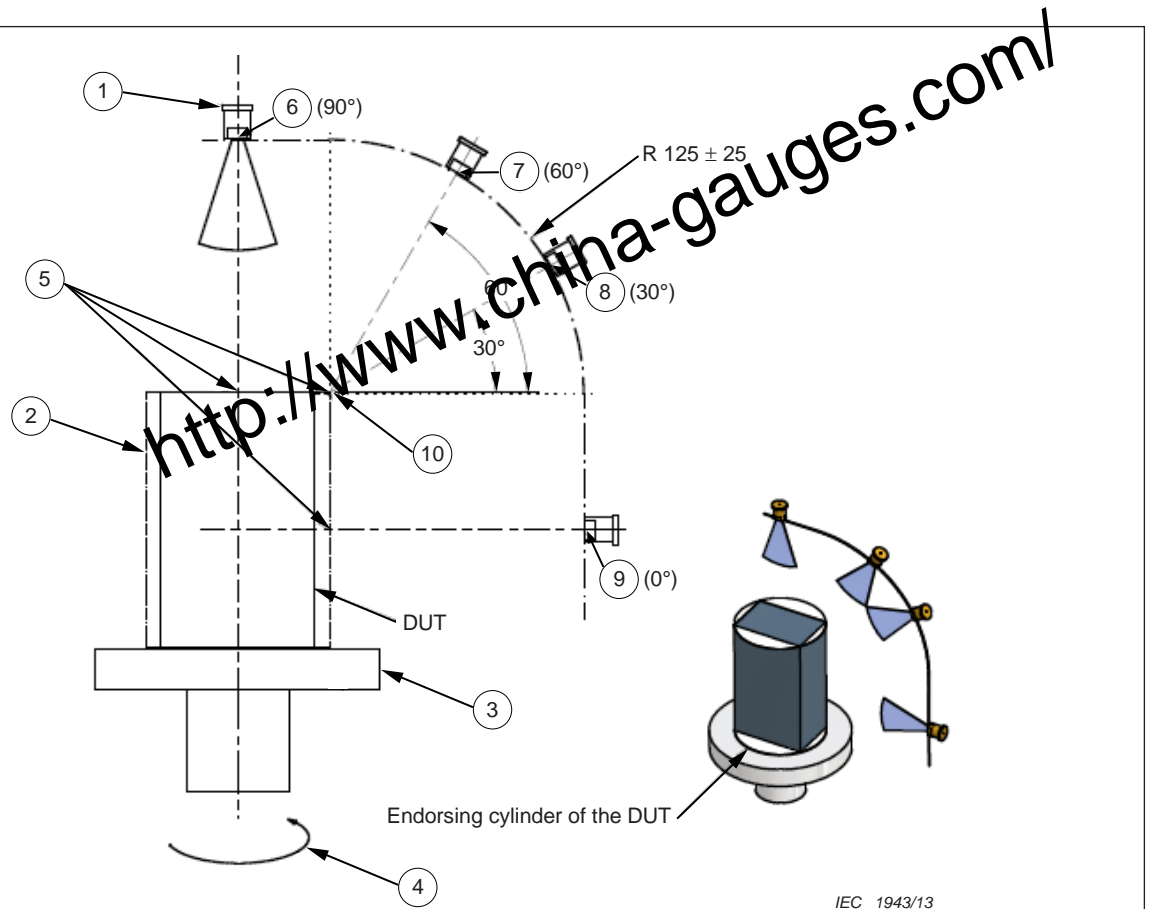

IEC 1943/13

Key

- | | | | |
|---|---|----|--|
| 1 | fan jet nozzle | 6 | position 1 of the nozzle (90°) |
| 2 | endorsing cylinder for DUT | 7 | position 2 of the nozzle (60°) |
| 3 | holder (rotating table) | 8 | position 3 of the nozzle (30°) |
| 4 | swivel axis (axis of rotation) | 9 | position 4 of the nozzle (0°) |
| 5 | reference point for 0°, for 30° and 60°, then for 90° versus the endorsing cylinder for DUT | 10 | centre point of circle R125 mm to locate nozzles |

Figure 12 — Test set-up for determining the protection against high-pressure and temperature water jet; degree of protection against ingress of water IP X9 for small enclosures

A2

ANNEXE A (informative)

ANNEX A (informative)

EXEMPLES DE CODIFICATION IP POUR LA VÉRIFICATION DE LA PROTECTION DE MATÉRIEL À BASSE TENSION CONTRE L'ACCÈS AUX PARTIES DANGEREUSES

EXAMPLES OF IP CODING FOR THE VERIFICATION OF PROTECTION OF LOW-VOLTAGE EQUIPMENT AGAINST ACCESS TO HAZARDOUS PARTS

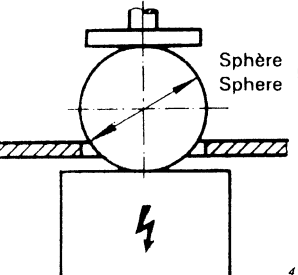
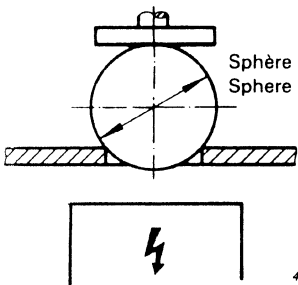
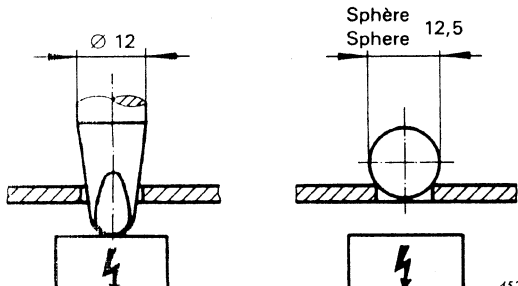
Réf. Ref. No.	Situation	Deux chiffres Two numerals	Lettre additionnelle Additional letter	Deux chiffres+lettre additionnelle Two numerals+additional letter
1	 <p>Sphère 50 Sphere 50</p> <p>450/89</p>	0X	—	0X
2	 <p>Sphère 50 Sphere 50</p> <p>451/89</p>	1X	A	1X
3	 <p>Ø 12</p> <p>Sphère 12,5 Sphere 12,5</p> <p>452/89</p>	1X	A	1X

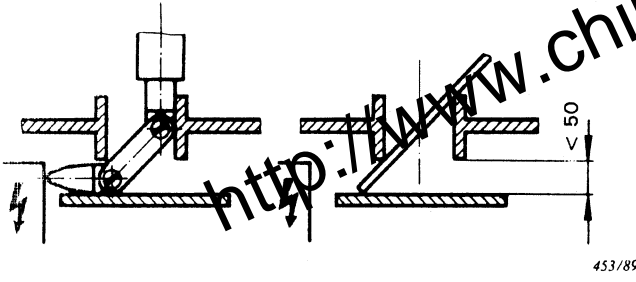
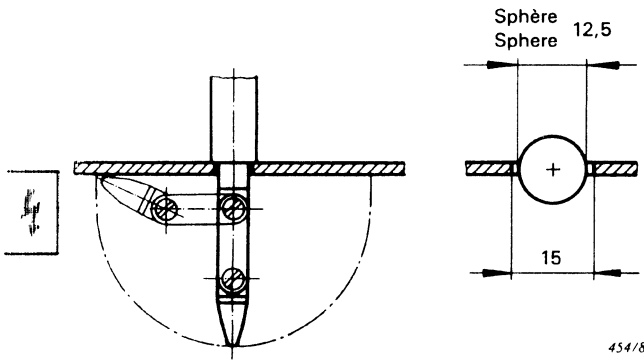
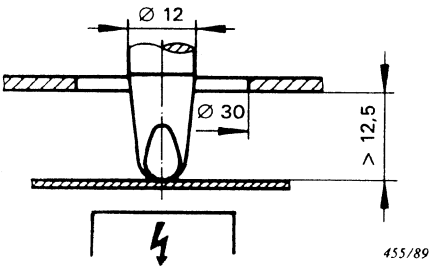
Réf. Ref. No.	Situation	Deux chiffres Two numerals	Lettre additionnelle Additional letter	Deux chiffres+lettre additionnelle Two numerals+ additional letter
4	 <p style="text-align: right;">453/89</p>	1X	A	1X
5	 <p style="text-align: right;">454/89</p>	1X	B	1XB
6	 <p style="text-align: right;">455/89</p>	1X	B	1XB

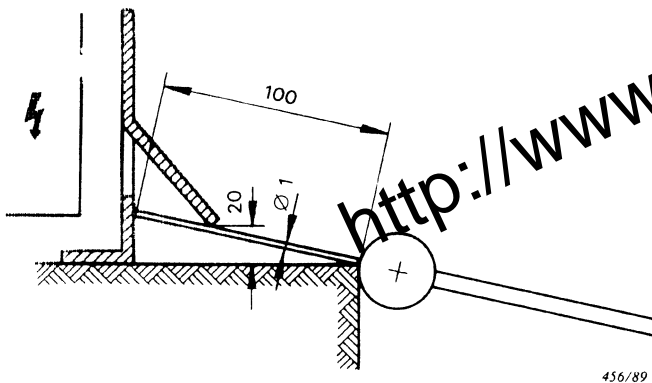
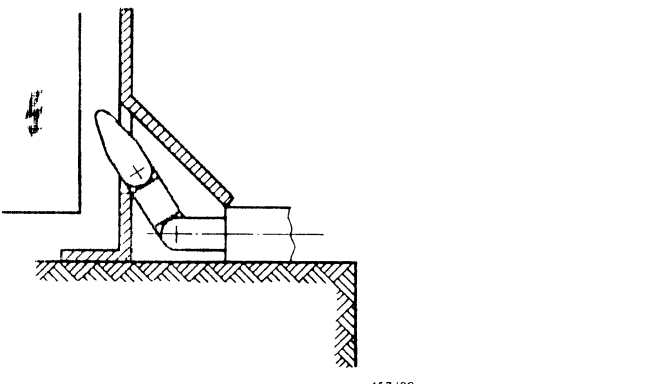
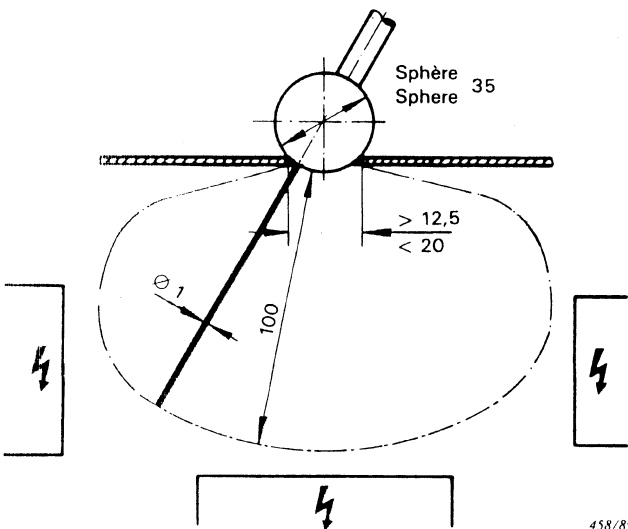
Réf. Ref. No.	Situation	Deux chiffres Two numerals	Lettre additionnelle Additional letter	Deux chiffres+lettre additionnelle Two numerals+additional letter
7	 	1X	D	1XD
8		1X	D	1XD

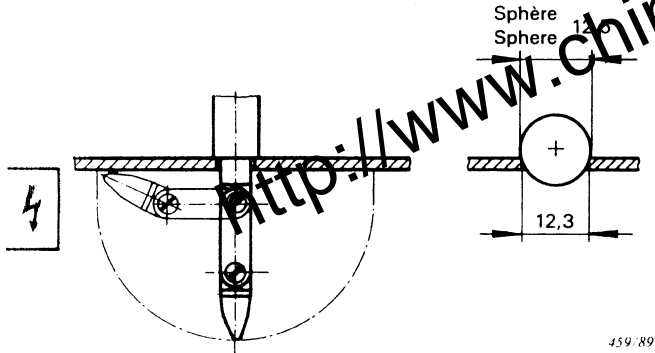
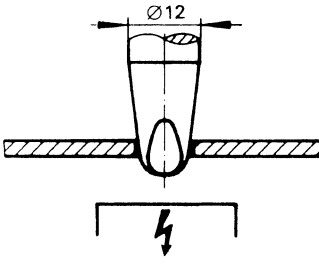
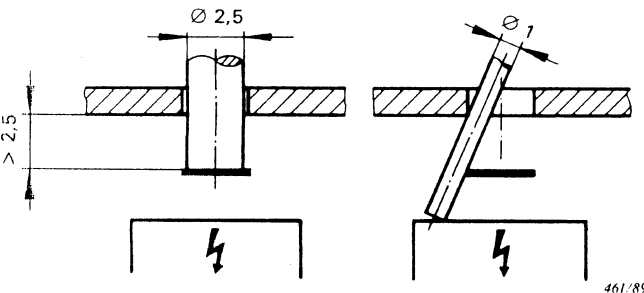
Réf. Ref. No.	Situation	Deux chiffres Two numerals	Lettre additionnelle Additional letter	Deux chiffres+lettre additionnelle Two numerals+ additional letter
9		2X	B	2X
10		2X	B	2X
11		2X	C	2XC

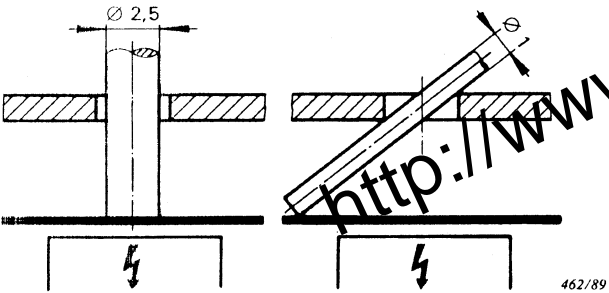
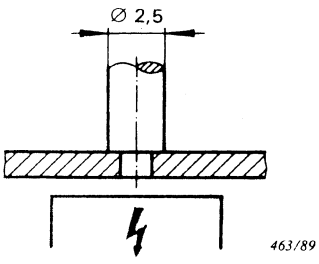
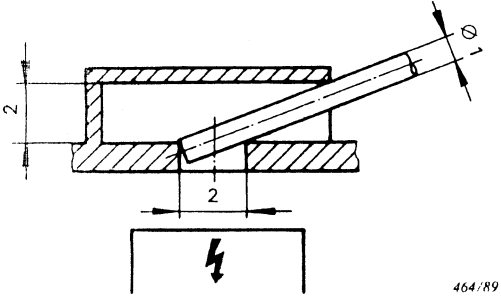
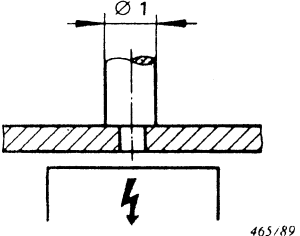
Réf. Ref. No.	Situation	Deux chiffres Two numerals	Lettre additionnelle Additional letter	Deux chiffres+lettre additionnelle Two numerals+ additional letter
12		2X	D	2XD
13		3X	C	3X
14		3X	D	3XD
15		4X	D	4X

Codes IP des exemples de l'annexe A
IP Codes of examples in Annex A

Premier chiffre caractéristique First characteristic numeral	Lettre additionnelle Additional letter				
	—	A	B	C	D
0	IPOX (1)	—	—	—	—
1	—	IP1X (2, 4)	IP1XB (5, 6)	—	IP1XD (7, 8)
2	—	—	IP2X (9, 10)	IP2XC (11)	IP2XD (12)
3	—	—	—	IP3X (13)	IP3XD (14)
4	—	—	—	—	IP4X (15)

NOTE Les nombres entre parenthèses sont les références de cette annexe.
The numerals in parentheses refer to the reference numbers in this annex.

Annex B (informative) Summary of responsibilities of relevant Technical Committees

The IP Code for classifying the degrees of protection provided by enclosures is intended to be used for most types of electrical equipment.

It should not be assumed that this standard is suitable to cover all specific details of the various types of equipment.

It is the responsibility of relevant Technical Committees to specify in their relevant product standards all details concerning the application of the IP Code to a particular type of equipment.

Marking with the IP Code indicates a claim for compliance with all the applicable requirements of this standard and also with any complementary requirements specified in the appropriate product standard.

The following list is given as a guide for the detailed information to be specified in product standards:

- 1) extent and manner to which the IP Code shall be used (see Clause 4);
- 2) definition of “enclosure” as it applies to the particular type of equipment (see Clause 2);
- 3) the protection of both the enclosure and the equipment inside the enclosure against external influences or conditions (see Clause 2);
- 4) degree of protection applied to hazardous moving parts (such as fans) external to the enclosure (see Clause 2);
- 5) the range of application if enclosures are exposed to temporary or continuous immersion (see Clause 6);
- 6) the application of “additional letters” for protection against access to hazardous parts provided by internal barriers or distances, if necessary (see Clause 7);
- 7) supplementary information to be given by “supplementary letters”, if any (see Clause 8);
- 8) the Secretariat of TC 70 shall be consulted before any new supplementary letter is introduced and the additional test procedure shall be stated (see Clause 8);
- 9) details for the marking (see Clause 10);
- 10) atmospheric conditions for testing if different from 11.1;
- 11) state and condition of test samples if different from the “general requirements for tests” (see 11.2);

- 12) details of test conditions (see 11.2) such as;
 - number of samples
 - mounting, assembling, positioning
 - pre-conditioning
 - whether energized or not
 - whether part in motion or not;
- 13) application of the general requirements for tests and the acceptance conditions on:
 - knock-holes and ventilation openings (see 11.3);
- 14) guidance for the interpretation of test results and for the acceptance conditions (see 11.3);
- 15) the working voltage, if applicable (see 12.3.1 and 12.3.2);
- 16) the category of the enclosure, indicating whether a pressure difference due to thermal cycling effects is present or not (see 13.4);
- 17) the location of the suction hole for the dust test if not in the vicinity of vulnerable parts (see 13.4);
- 18) the quantity and location of dust deposits permitted without affecting the safe operation (see 13.5.2);
- 19) the test device for IPX3 and IPX4 tests (oscillating tube or spray nozzle) (see 14.2.3 and 14.2.4);
- 20) the type of support for the enclosure (if not perforated) during IPX4 test (see 14.2.4);
- 21) the water temperature if the equipment is energized or running during the immersion test (see 14.2.7 d);
- 22) conditions for the continuous immersion test (see 14.2.8);
- 23) the acceptance conditions following the water tests, in particular the amount of water which may be allowed to enter and the details of any dielectric strength test (see 14.3);
- 24) the acceptance conditions if water can accumulate to reach live parts (see 14.3).
- ^{A2} 25) the temperature of the water for IPX9 test if different from 80 °C. ^{A2}

Bibliography

- IEC 61032, *Protection of persons and equipment by enclosures — Probes for verification*
- IEC 61140, *Protection against electric shock — Common aspects for Installation and equipment*

Annex ZA (normative)

Normative references to international publications with their corresponding European publications

When the international publication has been modified by CENELEC common modifications, indicated by (mod), the relevant EN/HD applies.

Publication	Year	Title	EN/HD	Year
IEC 60050-195	1998	<i>International Electrotechnical Vocabulary (IEV) Chapter 195: Earthing and protection against electric shock</i>	—	—
IEC 60050-826	1982	<i>Chapter 826: Electrical installations of buildings</i>	HD 384.2 S1	1986
IEC 60068-1	1988	<i>Environmental testing Part 1: General and guidance</i>	EN 60068-1 ^a	1994
IEC 60068-2-68	1994	<i>Part 2: Tests — Test L: Dust and sand</i>	EN 60068-2-68	1996
IEC 60071-2	1996	<i>Insulation co-ordination Part 2: Application guide</i>	EN 60071-2	1997

^a EN 60068-1 includes the corrigendum October 1988 and A1:1992 to IEC 60068-1.

National appendix NA (informative) Deletions from IEC Publication 529:1989

Foreword

The foreword has been deleted. It read as follows.

- 1) The formal decisions or agreements of the IEC on technical matters, prepared by Technical Committees on which all the National Committees having a special interest therein are represented, express, as nearly as possible, an international consensus of opinion on the subjects dealt with.
- 2) They have the form of recommendations for international use and they are accepted by the National Committees in that sense.
- 3) In order to promote international unification, the IEC expresses the wish that all National Committees should adopt the text of the IEC recommendation for their national rules in so far as national conditions will permit. Any divergence between the IEC recommendation and the corresponding national rules should, as far as possible, be clearly indicated in the latter.

Preface

The preface has been deleted. It read as follows.

This standard has been prepared by IEC Technical Committee No. 70: Degrees of protection by enclosures.

This second edition of IEC 529 replaces the first edition of 1976.

The text of this standard is based on the following documents:

Six Months' Rule	Report on Voting	Two Months' Procedure	Report on Voting
70(CO)13	70(CO)15	70(CO)16	70(CO)17

Full information on the voting for the approval of this standard can be found in the Voting Reports indicated in the above table.

The following IEC publications are quoted in this standard:

Publications Nos.	50(826) (1982):	International Electrotechnical Vocabulary (IEV), Chapter 826: Electrical installations of buildings.
	68-1 (1988):	Environmental testing, Part 1: <i>General and guidance</i> .
	71-2 (1976):	Insulation co-ordination, Part 2: <i>Application guide</i> .

National appendix NB (informative)

The United Kingdom participation in the preparation of this European Standard was entrusted by the General Electrotechnical Standards Policy Committee (GEL/-) to Technical Committee GEL/97 upon which the following bodies were represented:

Association of Manufacturers of Domestic Electrical Appliances
Consumer Policy Committee of BSI
Department of Trade and Industry (Consumer Safety Unit, CA Division)
Electrical Installation Equipment Manufacturers' Association (BEAMA Ltd.)
Engineering Equipment and Materials Users' Association
GAMBICA (BEAMA Ltd.)
Health and Safety Executive
Lighting Industry Federation Ltd.

<http://www.china-gauges.com/>

BSI — British Standards Institution

BSI is the independent national body responsible for preparing British Standards. It presents the UK view on standards in Europe and at the international level. It is incorporated by Royal Charter.

Revisions

British Standards are updated by amendment or revision. Users of British Standards should make sure that they possess the latest amendments or editions.

It is the constant aim of BSI to improve the quality of our products and services. We would be grateful if anyone finding an inaccuracy or ambiguity while using this British Standard would inform the Secretary of the technical committee responsible, the identity of which can be found on the inside front cover. Tel: 020 8996 9000. Fax: 020 8996 7400.

BSI offers members an individual updating service called PLUS which ensures that subscribers automatically receive the latest editions of standards.

Buying standards

Orders for all BSI, international and foreign standards publications should be addressed to Customer Services. Tel: 020 8996 9001. Fax: 020 8996 7001.

In response to orders for international standards, it is BSI policy to supply the BSI implementation of those that have been published as British Standards, unless otherwise requested.

Information on standards

BSI provides a wide range of information on national, European and international standards through its Library and its Technical Help to Exporters Service. Various BSI electronic information services are also available which give details on all its products and services. Contact the Information Centre. Tel: 020 8996 7111. Fax: 020 8996 7048.

Subscribing members of BSI are kept up to date with standards developments and receive substantial discounts on the purchase price of standards. For details of these and other benefits contact Membership Administration. Tel: 020 8996 7002. Fax: 020 8996 7001.

Copyright

Copyright subsists in all BSI publications. BSI also holds the copyright, in the UK, of the publications of the international standardization bodies. Except as permitted under the Copyright, Designs and Patents Act 1988 no extract may be reproduced, stored in a retrieval system or transmitted in any form or by any means – electronic, photocopying, recording or otherwise – without prior written permission from BSI.

This does not preclude the free use, in the course of implementing the standard, of necessary details such as symbols, and size, type or grade designations. If these details are to be used for any other purpose than implementation then the prior written permission of BSI must be obtained.

If permission is granted, the terms may include royalty payments or a licensing agreement. Details and advice can be obtained from the Copyright Manager. Tel: 020 8996 7070.