

BS EN 60947-4-2:2012

Incorporating Corrigendum July 2012



BSI Standards Publication

<http://www.china-gauges.com/>

Low-voltage switchgear and controlgear

Part 4-2: Contactors and motor-starters
— AC semiconductor motor controllers
and starters

bsi.

...making excellence a habit.™

National foreword

This British Standard is the UK implementation of EN 60947-4-2:2012. It is identical to IEC 60947-4-2:2011, incorporating corrigendum July 2012. It supersedes BS EN 60947-4-2:2000, which will be withdrawn on 22 June 2014.

The UK participation in its preparation was entrusted by Technical Committee PEL/17, Switchgear, controlgear, and HV-LV co-ordination, to Subcommittee PEL/17/2, Low voltage switchgear and controlgear.

A list of organizations represented on this subcommittee can be obtained on request to its secretary.

This publication does not purport to include all the necessary provisions of a contract. Users are responsible for its correct application.

© The British Standards Institution 2012

Published by BSI Standards Limited 2012

ISBN 978 0 580 80313 0

ICS 29.130.20

Compliance with a British Standard cannot confer immunity from legal obligations.

This British Standard was published under the authority of the Standards Policy and Strategy Committee on 31 July 2012.

Amendments/corrigenda issued since publication

Date	Text affected
31 August 2012	Implementation of IEC corrigendum July 2012: Table 19 modified

English version

**Low-voltage switchgear and controlgear -
Part 4-2: Contactors and motor-starters -
AC semiconductor motor controllers and starters**
(IEC 60947-4-2:2011)

Appareillage à basse tension -
Partie 4-2: Contacteurs et démarreurs de
moteurs -
Gradateurs et démarreurs à
semiconducteurs de moteurs à courant
alternatif
(CEI 60947-4-2:2011)

Niederspannungsschaltgeräte -
Teil 4-2: Schütze und Motorstarter -
Halbleiter-Motor-Steuergeräte und -Starter
für Wechselspannungen
(IEC 60947-4-2:2011)

This European Standard was approved by CENELEC on 2011-06-22. CENELEC members are bound to comply with the CEN/CENELEC Internal Regulations which stipulate the conditions for giving this European Standard the status of a national standard without any alteration.

Up-to-date lists and bibliographical references concerning such national standards may be obtained on application to the CEN-CENELEC Management Centre or to any CENELEC member.

This European Standard exists in three official versions (English, French, German). A version in any other language made by translation under the responsibility of a CENELEC member into its own language and notified to the CEN-CENELEC Management Centre has the same status as the official versions.

CENELEC members are the national electrotechnical committees of Austria, Belgium, Bulgaria, Croatia, Cyprus, the Czech Republic, Denmark, Estonia, Finland, France, Germany, Greece, Hungary, Iceland, Ireland, Italy, Latvia, Lithuania, Luxembourg, Malta, the Netherlands, Norway, Poland, Portugal, Romania, Slovakia, Slovenia, Spain, Sweden, Switzerland, Turkey and the United Kingdom.

CENELEC

European Committee for Electrotechnical Standardization
Comité Européen de Normalisation Electrotechnique
Europäisches Komitee für Elektrotechnische Normung

Management Centre: Avenue Marnix 17, B - 1000 Brussels

Foreword

The text of document (17B/1734/FDIS), future edition 3 of IEC 60947-4-2, prepared by SC 17B, "Low-voltage switchgear and controlgear", of IEC TC 17, "Switchgear and controlgear", was submitted to the IEC-CENELEC parallel vote and approved by CENELEC as EN 60947-4-2:2012.

The following dates are fixed:

- latest date by which the document has to be implemented at national level by publication of an identical national standard or by endorsement (dop) 2012-12-29
- latest date by which the national standards conflicting with the document have to be withdrawn (dow) 2014-06-22

This European Standard supersedes EN 60947-4-2:2000 + A1:2002 + A2:2006.

EN 60947-4-2:2012 includes the following significant technical changes with respect to EN 60947-4-2:2000 + A1:2002 + A2:2006:

- updated EMC normative references and associated requirements,
- new references to EN 60947-1,
- marking of electronic relays without thermal memory,
- marking of tripping time at 0 °C ambient or below,
- new test requirements for limits of operation of time-delay overload relays,
- new classes of overload current withstand time,
- damp heat, salt mist, vibration and shock tests,
- short-circuit test in the smallest enclosure,
- update of the routine and sampling tests.

Attention is drawn to the possibility that some of the elements of this document may be the subject of patent rights. CEN and CENELEC shall not be held responsible for identifying any or all such patent rights.

This standard shall be read in conjunction with EN 60947-1:2007, *Low-voltage switchgear and controlgear – Part 1: General rules*. The provisions of the general rules are applicable to this standard, where specifically called for.

This standard covers the Principle Elements of the Safety Objectives for Electrical Equipment Designed for Use within Certain Voltage Limits (LVD - 2006/95/EC).

This document has been prepared under a mandate given to CENELEC by the European Commission and the European Free Trade Association, and supports essential requirements of EU Directive(s).

For the relationship with EU Directive(s) see informative Annex ZZ, which is an integral part of this document.

Endorsement notice

The text of the International Standard IEC 60947-4-2:2011 was approved by CENELEC as a European Standard without any modification.

In the official version, for Bibliography, the following notes have to be added for the standards indicated:

IEC 60146 series	NOTE Harmonized in EN 60146 series (not modified).
IEC 60255 series	NOTE Harmonized in EN 60255 series (partially modified).
IEC 60947-5 series	NOTE Harmonized in EN 60947-5 series (partially modified).
IEC 61000-3-2:2005 + A1: 2008 + A2: 2009	NOTE Harmonized as EN 61000-3-2:2006 + A1:2009 + A2:2009 (not modified).
IEC 61000-4-2:2008	NOTE Harmonized as EN 61000-4-2:2009 (not modified).
IEC 61000-4-3:2006 + A1: 2007 + A2: 2010	NOTE Harmonized as EN 61000-4-3:2006 + A1:2008 + A2:2010 (not modified).
IEC 61000-4-4:2004 + A1: 2010	NOTE Harmonized as EN 61000-4-4:2004 + A1:2010 (not modified).
IEC 61000-4-5:2005	NOTE Harmonized as EN 61000-4-5:2006 (not modified).
IEC 61000-4-6:2008	NOTE Harmonized as EN 61000-4-6:2009 (not modified).
IEC 61000-4-11:2004	NOTE Harmonized as EN 61000-4-11:2004 (not modified).
IEC 61131-2:2007	NOTE Harmonized as EN 61131-2:2007 (not modified).

Annex ZA
(normative)

**Normative references to international publications
with their corresponding European publications**

The following referenced documents are indispensable for the application of this document. For dated references, only the edition cited applies. For undated references, the latest edition of the referenced document (including any amendments) applies.

NOTE When an international publication has been modified by common modifications, indicated by (mod), the relevant EN/HD applies.

<u>Publication</u>	<u>Year</u>	<u>Title</u>	<u>EN/HD</u>	<u>Year</u>
IEC 60034-1 (mod)	2010	Rotating electrical machines - Part 1: Rating and performance	EN 60034-1 + corr. October	2010 2010
IEC 60085	2007	Electrical insulation - Thermal evaluation and designation	EN 60085	2008
IEC 60269-1 + A1	2006 2009	Low-voltage fuses - Part 1: General requirements	EN 60269-1 + A1	2007 2009
IEC 60410	1973	Sampling plans and procedures for inspection by attributes	-	-
IEC 60664	Series	Insulation coordination for equipment within low-voltage systems	EN 60664	Series
IEC 60947-1	2007	Low-voltage switchgear and controlgear - Part 1: General rules	EN 60947-1	2007
IEC 61000-4	Series	Electromagnetic compatibility (EMC) - Part 4: Testing and measurement techniques -	EN 61000-4	Series
CISPR 11 (mod) + A1	2009 2010	Industrial, scientific and medical equipment - Radio-frequency disturbance characteristics - Limits and methods of measurement	EN 55011 + A1	2009 2010

Annex ZZ
(informative)

Coverage of Essential Requirements of EU Directives

This European Standard has been prepared under a mandate given to CEN/LEC by the European Commission and the European Free Trade Association and within its scope the standard covers all relevant essential requirements as given in Article 1 of Annex I of the Directive 2004/108/EC.

Compliance with this standard provides one means of conformity with the specified essential requirements of the Directive concerned.

WARNING - Other requirements and other EU Directives may be applicable to the products falling within the scope of this standard.

<http://www.china-gauges.com/>

CONTENTS

INTRODUCTION	8
1 Scope	9
2 Normative references	10
3 Terms, definitions, symbols and abbreviations	10
3.1 General	10
3.2 Alphabetical index of terms	10
3.3 Terms and definitions concerning a.c. semiconductor motor controllers and starters	12
3.4 Terms and definitions concerning d.c. motor controllers and starters	14
3.5 Terms and definitions concerning EMC definitions	18
3.6 Symbols and abbreviations	19
4 Classification	19
5 Characteristics of a.c. semiconductor motor controllers and starters	20
5.1 Summary of characteristics	20
5.2 Type of equipment	20
5.2.1 Form of equipment	20
5.2.2 Number of poles	20
5.2.3 Kind of current	20
5.2.4 Interrupting medium (air, vacuum, etc.)	20
5.2.5 Operating conditions of the equipment	20
5.3 Rated and limiting values for main circuits	21
5.3.1 Rated voltages	21
5.3.2 Currents	23
5.3.3 Rated frequency	23
5.3.4 Rated duty	23
5.3.5 Normal load and overload characteristics	24
5.3.6 Rated conditional short-circuit current	25
5.4 Utilization category	25
5.4.1 General	25
5.4.2 Assignment of ratings based on the results of tests	26
5.5 Control circuits	27
5.6 Auxiliary circuits	27
5.7 Characteristics of relays and releases (overload relays)	27
5.7.1 Summary of characteristics	28
5.7.2 Types of relay or release	28
5.7.3 Characteristic values	28
5.7.4 Designation and current settings of overload relays	29
5.7.5 Time-current characteristics of overload relays	29
5.7.6 Influence of ambient air temperature	30
5.8 Co-ordination with short-circuit protective devices (SCPD)	30
6 Product information	30
6.1 Nature of information	30
6.2 Marking	31
6.3 Instructions for installation, operation, and maintenance	31
7 Normal service, mounting and transport conditions	32

7.1	Normal service conditions	32
7.1.1	Ambient air temperature	32
7.1.2	Altitude	32
7.1.3	Atmospheric conditions	32
7.1.4	Shock and vibrations	32
7.2	Conditions during transport and storage	32
7.3	Mounting	32
7.4	Electrical system disturbances and influences	32
8	Constructional and performance requirements	33
8.1	Constructional requirements	33
8.1.1	General	33
8.1.2	Materials	33
8.1.3	Current-carrying parts and their connections	33
8.1.4	Clearances and creepage distances	33
8.1.5	Actuator	33
8.1.6	Indication of the contact position	33
8.1.7	Additional requirements for equipment suitable for isolation	33
8.1.8	Terminals	33
8.1.9	Additional requirements for equipment provided with a neutral pole	34
8.1.10	Provisions for protective earthing	34
8.1.11	Enclosures for equipment	34
8.1.12	Degrees of protection of enclosed equipment	34
8.1.13	Conduit pull-out, torque and bending with metallic conduits	34
8.2	Performance requirements	34
8.2.1	Operating conditions	34
8.2.2	Temperature rise	38
8.2.3	Dielectric properties	41
8.2.4	Normal load and overload performance requirements	42
8.2.5	Co-ordination with short-circuit protective devices	47
8.3	EMC requirements	47
8.3.1	General	47
8.3.2	Emission	48
8.3.3	Immunity	48
9	Tests	50
9.1	Kinds of tests	50
9.1.1	General	50
9.1.2	Type tests	50
9.1.3	Routine tests	50
9.1.4	Sampling tests	50
9.1.5	Special tests	51
9.2	Compliance with constructional requirements	51
9.3	Compliance with performance requirements	51
9.3.1	Test sequences	51
9.3.2	General test conditions	52
9.3.3	Performance under no load, normal load, and overload conditions	52
9.3.4	Performance under short-circuit conditions	62
9.3.5	EMC tests	65
9.3.6	Routine and sampling tests	68
	Annex A (normative) Marking and identification of terminals	70

Annex B Vacant	73
Annex C (normative) Co-ordination at the crossover current between the starter and associated SCPD	74
Annex D Vacant	75
Annex E Vacant	79
Annex F (informative) Operating capability	80
Annex G (informative) Examples of control circuit configurations	83
Annex H Vacant	85
Annex I (normative) Modified test circuit for short-circuit testing of semiconductor motor controllers and starters	86
Annex J (informative) Flowchart for constructing bypassed semiconductor controllers tests	88
Annex K (normative) External functions within electronic overload relays	89
Bibliography	94
Figure 1 – Semiconductor motor control devices	13
Figure 2 – Connecting methods	22
Figure 3 – Thermal memory test	36
Figure 4 – Multiple of current setting limits for ambient air temperature compensated time-delay overload relays	62
Figure C.1 – Examples of time-current withstand characteristic	77
Figure F.1 – Thermal stability test profile	80
Figure F.2 – Overload capability test profile	81
Figure F.3 – Blocking and commutating capability test profile	82
Figure G.1 – Diagrammatic representation of an ECD	83
Figure G.2 – Single supply and control input	83
Figure G.3 – Single supply and control input	84
Figure G.4 – Controllers with an internal control supply and control input only	84
Figure I.1 – Modified circuit for short-circuit testing of semiconductor devices	86
Figure I.2 – Time line for the short-circuit test of 9.3.4.1.6	87
Figure K.1 – Test circuit for the verification of the operating characteristic of a residual current electronic overload relay	93
Table 1 – Functional possibilities of semiconductor motor control devices	14
Table 2 – Utilization categories	26
Table 3 – Relative levels of severity	27
Table 4 – Trip classes of overload relays	29
Table 5 – Limits of operation of time-delay overload relays when energized on all poles	35
Table 6 – Limits of operation of three-pole time-delay overload relays when energized on two poles only	37
Table 7 – Temperature rise limits for insulated coils in air and in oil	40
Table 8 – Intermittent duty test cycle data	40
Table 9 – Minimum overload current withstand time (T_x) in relation to overload current ratio (X) and corresponding to overload relay trip class (see Table 19)	43
Table 10 – Minimum requirements for thermal stability test conditions ^a	43

Table 11 – Minimum requirements for overload capability test conditions 44

Table 12 – Minimum requirements and conditions for performance testing with an induction motor load 44

Table 13 – Making and breaking capacity test; making and breaking conditions according to utilization categories for the mechanical switching device of hybrid motor controllers H1, H2, H3 and for certain forms of bypassed controllers 46

Table 14 – Conventional operational performance making and breaking conditions according to utilization categories for the mechanical switching device of hybrid motor controllers H1B, H2B, H3B and for certain forms of bypassed controllers 46

Table 15 – Specific acceptance or performance criteria when EM disturbances are present 49

Table 16 – Thermal stability test specifications 57

Table 17 – Initial case temperature requirements 57

Table 18 – Blocking and commutating capability test specifications 59

Table 19 – Terminal disturbance voltage limits for conducted radio-frequency emission 67

Table 20 – Radiated emissions test limits 67

Table A.1 – Main circuit terminal markings 70

Table C.1 – Test conditions 76

Table K.1 – Operating time of residual current electronic overload relays 90

<http://www.china-gauges.com/>

INTRODUCTION

This standard covers low-voltage a.c. semiconductor motor controllers and starters that have many capabilities and features beyond the simple starting and stopping of an induction motor, such as controlled starting and stopping, manoeuvring and controlled running.

The generic term “controller” is used in this standard wherever the unique features of the power semiconductor switching elements are the most significant points of interest. The generic term “starter” is used wherever the consequences of operating the power semiconductor switching elements, together with suitable overcurrent protective means, are the most significant points of interest. Specific designations (for example form 1, form HxB, etc.) are used wherever the unique features of various configurations comprise significant points of interest.

<http://www.china-gauges.com/>

LOW-VOLTAGE SWITCHGEAR AND CONTROLGEAR –

Part 4-2: Contactors and motor-starters – AC semiconductor motor controllers and starters

1 Scope

This standard applies to a.c. semiconductor motor controllers and starters, which may include a series mechanical switching device, intended to be connected to circuits, the rated voltage of which does not exceed 1 000 V a.c.

This standard characterises a.c. semiconductor motor controllers and starters with and without bypass means.

AC semiconductor motor controllers and starters dealt with in this standard are not normally designed to interrupt short-circuit currents. Therefore, suitable short-circuit protection (see 8.2.5) should form part of the installation, but not necessarily of the a.c. semiconductor motor controller or starter.

In this context, this standard gives requirements for a.c. semiconductor motor controllers and starters associated with separate short-circuit protective devices.

This standard does not apply to

- continuous operation of a.c. motors at motor speeds other than the normal speed;
- semiconductor equipment, including semiconductor contactors (see 2.2.13 of IEC 60947-1:2007) controlling non-motor loads;
- electronic a.c. power controllers covered by IEC 60146 series.

Contactors, overload relays and control circuit devices used in a.c. semiconductor motor controllers and starters should comply with the requirements of their relevant product standard. Where mechanical switching devices are used, they should meet the requirements of their own IEC product standard, and the additional requirements of this standard.

The object of this standard is to state as follows:

- the characteristics of a.c. semiconductor motor controllers and starters and associated equipment;
- the conditions with which a.c. semiconductor motor controllers and starters comply with reference to
 - a) their operation and behaviour;
 - b) their dielectric properties;
 - c) the degrees of protection provided by their enclosures where applicable;
 - d) their construction;
- the tests intended for confirming that these conditions have been met, and the methods to be adopted for these tests;
- the information to be given with the equipment, or in the manufacturer's literature.

NOTE For the purpose of this standard, the term "controller" may be used instead of "a.c. semiconductor motor controller".

2 Normative references

The following referenced documents are indispensable for the application of this document. For dated references, only the edition cited applies. For undated references, the latest edition of the referenced document (including any amendments) applies.

IEC 60034-1:2010, *Rotating electrical machines – Part 1: Rating and performance*

IEC 60085:2007, *Electrical insulation – Thermal evaluation and designation*

IEC 60269-1:2006, *Low-voltage fuses – Part 1: General requirements*
Amendment 1 (2009)

IEC 60410:1973, *Sampling plans and procedures for inspection by attributes*

IEC 60664 (all parts), *Insulation coordination for equipment within low-voltage systems*

IEC 60947-1:2007, *Low-voltage switchgear and controlgear – Part 1: General rules*

IEC 61000-4 (all parts), *Electromagnetic compatibility (EMC) – Part 4: Testing and measurement techniques*

CISPR 11:2009, *Industrial, scientific and medical equipment – Radio-frequency disturbance characteristics – Limits and methods of measurement*
Amendment 1 (2010)

3 Terms, definitions, symbols and abbreviations

3.1 General

For the purposes of this document, the terms and definitions of Clause 2 of IEC 60947-1:2007, as well as the following terms, definitions, symbol and abbreviations apply.

3.2 Alphabetical index of terms

	Reference
A	
a.c. semiconductor motor controller	3.3.2
B	
burst (of pulses or oscillations)	3.5.7
bypassed controller.....	3.4.31
C	
CO operation	3.4.32
controlled acceleration	3.4.6
controlled deceleration.....	3.4.7
controlled running	3.4.8
current-limit function	3.4.4
E	
electromagnetic compatibility [EMC]	3.5.1
electromagnetic disturbance	3.5.3
electromagnetic emission.....	3.5.2

F	
FULL-ON (state of controllers)	3.4.12
H	
hybrid motor controller or starter, form HxA (where x = 1, 2 or 3)	3.4.1
hybrid motor controller or starter, form HxB	3.4.2
I	
inhibit time	3.4.28
J	
jam sensitive electronic overload relay	3.4.27
M	
manoeuvre	3.4.5
minimum load current	3.4.13
O	
O operation	3.4.33
OFF-state	3.4.14
OFF-state leakage current [I_L]	3.4.15
OFF-time	3.4.30
ON-state	3.4.11
ON-time	3.4.29
OPEN position	3.4.3
operating capability	3.4.18
operating cycle (of a controller)	3.4.17
operation (of a controller)	3.4.16
overload current profile	3.4.19
P	
phase loss sensitive overload relay or release	3.4.23
prospective current (of a circuit and with respect to a switching device or a fuse)	3.4.9
prospective locked rotor current [I_{LRP}]	3.4.10
R	
radio (frequency) disturbance	3.5.4
radio frequency interference [RFI]	3.5.5
rating index	3.4.20
S	
semiconductor direct on line (DOL) motor controller (form 3)	3.3.5
semiconductor motor controller (form 1)	3.3.3
semiconductor motor starter (form 1, form 2, form 3)	3.3.6
semiconductor soft-start motor controller (form 2)	3.3.4
semiconductor switching device	3.3.1
stall sensitive electronic overload relay	3.4.26
T	
transient (adjective and noun)	3.5.6
trip-free controller or starter	3.4.22
tripping operation (of a controller or starter)	3.4.21
U	
under-current relay or release	3.4.24
under-voltage relay or release	3.4.25

<http://www.china-gauges.com/>

V

voltage surge 3.5.8

3.3 Terms and definitions concerning a.c. semiconductor motor controllers and starters

3.3.1

semiconductor switching device

switching device designed to make and/or break the current in an electric circuit by means of the controlled conductivity of a semiconductor

NOTE This definition differs from IEC 60050-441:1984 and IEC 60050-441:2014-03 since a semiconductor switching device is also designed for breaking the current.

[IEC 60947-1:2007, 2.2.3]

3.3.2

a.c. semiconductor motor controller

semiconductor switching device that provides the starting function for an a.c. motor and an OFF-state

NOTE 1 Because dangerous levels of leakage currents can exist in a semiconductor motor controller in the OFF-state, the load terminals should be considered as live parts at all times.

NOTE 2 In a circuit where the current passes through zero (alternately or otherwise), the effect of "not making" the current following such a zero value is equivalent to breaking the current.

3.3.3

semiconductor motor controller (form 1)

a.c. semiconductor motor controller, in which the starting function may comprise any starting method specified by the manufacturer, and that provides control functions which may include any combination of manoeuvring, controlled acceleration, running or controlled deceleration of an a.c. motor. A FULL-ON state may also be provided

NOTE See Figure 1 and Table 1.

3.3.4

semiconductor soft-start motor controller (form 2)

special form of a.c. semiconductor motor controller, in which the starting function is limited to a voltage and/or current ramp which may include controlled acceleration, and where the additional control function is limited to providing FULL-ON

NOTE See Figure 1 and Table 1.

3.3.5

semiconductor direct on line (DOL) motor controller (form 3)

special form of a.c. semiconductor motor controller, in which the starting function is limited to a full-voltage, unramped starting method only, and where the additional control function is limited to providing FULL-ON

NOTE See Figure 1 and Table 1.

3.3.6

semiconductor motor starter (form 1, form 2, form 3)

a.c. semiconductor motor controller with suitable overload protection, rated as a unit

NOTE See Figure 1 and Table 1.

<http://www.china-gauges.com/>

<p>Device</p>			
<p>Semiconductor motor starter (forms 1, 2, 3)</p>			
<p>Hybrid motor controller HxA^a where x = 1, 2 or 3</p>			
<p>Hybrid motor controller HxB^b</p>			
<p>Bypassed controller</p>			
<p>Bypassed hybrid motor controller^c</p>			
<p>Hybrid motor starter</p>	<p>Form H1A or H1B with motor overload protection</p>	<p>Form H2A or H2B with motor overload protection</p>	<p>Form H3A or H3B with motor overload protection</p>
<p>^a Two separate controls for the controller and the series mechanical switching device. ^b One control only for the series mechanical switching device. ^c For other configurations, tests may be suitably adapted by agreement between the user and the manufacturer.</p>			

Figure 1 – Semiconductor motor control devices

Table 1 – Functional possibilities of semiconductor motor control devices

Device	Form 1	Form 2	Form 3
Semiconductor motor controller	<ul style="list-style-type: none"> - OFF - Starting function - Manoeuvring - Controlled acceleration - Running - FULL ON - Controlled deceleration 	<ul style="list-style-type: none"> - OFF state - Starting function - Controlled acceleration - FULL ON 	Not available
Semiconductor DOL motor controller	Not available	Not available	<ul style="list-style-type: none"> - OFF state - Starting function - FULL ON
Semiconductor motor starter	Form 1 controller with motor overload protection	Form 2 controller with motor overload protection	Not available
Semiconductor DOL motor starter	Not available	Not available	Form 3 DOL motor controller with motor overload protection
Hybrid motor controller HxA ^a where x = 1, 2 or 3	H1A: <ul style="list-style-type: none"> - Open - OFF state - Starting function - Manoeuvring - Controlled acceleration - Running - Full ON - Controlled deceleration 	H2A: <ul style="list-style-type: none"> - Open - OFF state - Starting function - Controlled acceleration - FULL ON 	H3A: <ul style="list-style-type: none"> - Open - OFF state - Starting function - FULL ON
Hybrid motor controller HxB ^b where x = 1, 2 or 3	H1B: <ul style="list-style-type: none"> - Open - Starting function - Manoeuvring - Controlled acceleration - Running - FULL ON - Controlled deceleration 	H2B: <ul style="list-style-type: none"> - Open - Starting function - Controlled acceleration - FULL ON 	H3B: <ul style="list-style-type: none"> - Open - Starting function - FULL ON
Hybrid motor starter	Form H1A or H1B with motor overload protection	Form H2A or H2B with motor overload protection	Form H3A or H3B with motor overload protection
^a Two separate controls for the controller and the series mechanical switching device. ^b One control only for the series mechanical switching device.			

3.4 Terms and definitions concerning hybrid motor controllers and starters

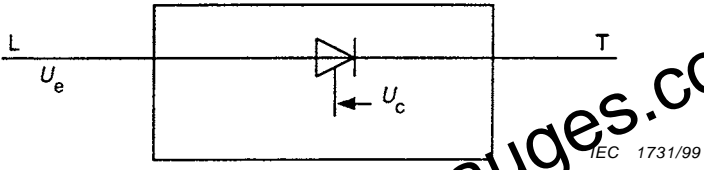
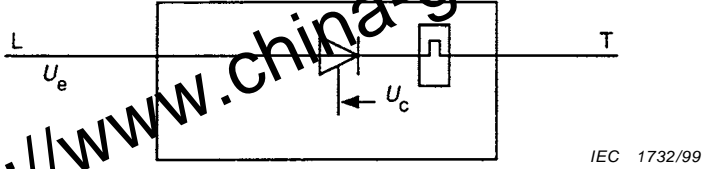
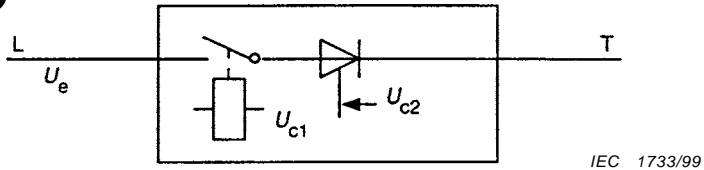
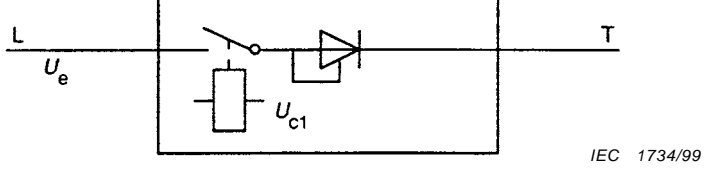
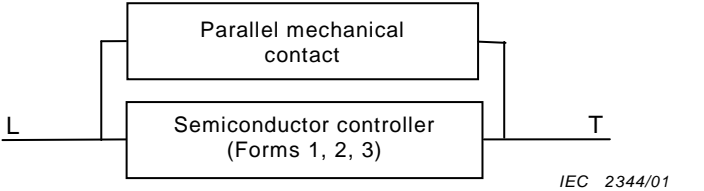
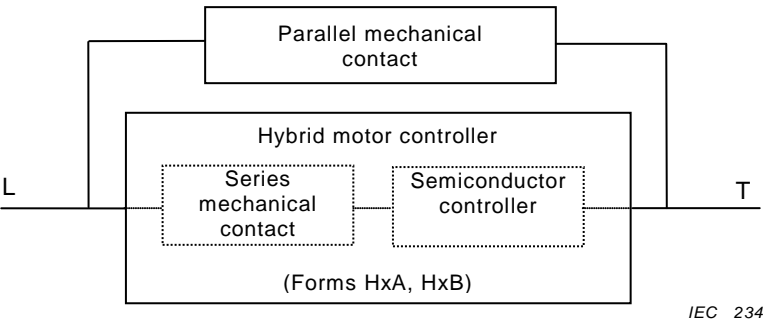
3.4.1

hybrid motor controller or starter, form HxA (where x = 1, 2 or 3)

form 1, 2 or 3 semiconductor motor controller or starter in series with a mechanical switching device, all rated as a unit

NOTE 1 Separate control commands are provided for the series mechanical switching device and the semiconductor motor controller or starter. All the control functions appropriate to the form of motor controller or starter specified are provided, together with an OPEN position.

NOTE 2 See Figure 1.

3.4.2

hybrid motor controller or starter, form HxB

form 1, 2 or 3 semiconductor motor controller or starter in series with a mechanical switching device, all rated as a unit. A single control command is provided for both the series mechanical switching device and the semiconductor motor controller or starter

NOTE 1 All the control functions appropriate to the form of motor controller specified are provided, with the exception of an OFF state.

NOTE 2 See Figure 1.

3.4.3

OPEN position

condition of a hybrid semiconductor motor controller or starter when the series mechanical switching device is in the OPEN position

[2.4.21 of IEC 60947-1:2007, modified]

3.4.4

current-limit function

ability of the controller to limit the motor current to a specified value

NOTE It does not include the ability to limit the instantaneous current under conditions of short circuit.

3.4.5

manoeuvre

any deliberate operation that causes current changes which must be characterized and controlled (for example jogging, braking)

NOTE 1 Starting is a mandatory manoeuvre that is recognized separately.

NOTE 2 Braking operations performed by the a.c. semiconductor motor controller or starter are considered to be a manoeuvre within the scope of this standard.

3.4.6

controlled acceleration

control of motor performance while increasing motor speed by acting on the motor supply

3.4.7

controlled deceleration

control of motor performance while decreasing motor speed by acting on the motor supply

3.4.8

controlled running

control of motor performance by acting on the motor supply while the motor is running at normal speed (for example energy saving)

3.4.9

prospective current (of a circuit and with respect to a switching device or a fuse)

current that would flow in the circuit if each pole of the switching device or the fuse were replaced by a conductor of negligible impedance

NOTE The method to be used to evaluate and to express the prospective current is to be specified in the relevant product standard.

[IEC 60947-1:2007, 2.5.5]

3.4.10

prospective locked rotor current

I_{LRP}

prospective current that would flow when the rated voltage is applied to the motor with a locked rotor

3.4.11

ON-state

the condition of a controller when the conduction current can flow through its main circuit

3.4.12

FULL-ON (state of controllers)

the condition of a controller when the controlling functions are set to provide normal full voltage excitation to the load

3.4.13

minimum load current

minimum operational current in the main circuit which is necessary for correct action of a controller in the ON-state

NOTE The minimum load current should be given as the r.m.s value.

3.4.14

OFF-state

the condition of a controller when no control signal is applied, and no current exceeding the OFF-state leakage current flows through the main circuit

3.4.15

OFF-state leakage current

I_L

the current which flows through the main circuit of a controller in the OFF-state

3.4.16

operation (of a controller)

transition from the ON-state to the OFF-state, or the reverse

3.4.17

operating cycle (of a controller)

succession of operations from one state to the other and back to the first state

NOTE A succession of operations not forming an operating cycle is referred to as an operating series.

3.4.18

operating capability

under prescribed conditions, the ability to perform a series of operating cycles without failure

3.4.19

overload current profile

current-time co-ordinate specifying the requirement to accommodate overload currents for a period of time

NOTE See 5.3.5.1.

3.4.20

rating index

rating information organized in a prescribed format, unifying rated operational current and the corresponding utilization category, overload current profile, and the duty cycle or OFF-time

NOTE See 6.1e).

3.4.21

tripping operation (of a motor controller or starter)

operation to establish and maintain an OFF-state (or open position in the case of a form HxB motor controller or starter) initiated by a control signal

3.4.22

trip-free controller or starter

controller or starter which establishes and sustains an OFF-state condition, which cannot be overridden in the presence of a trip condition

NOTE In the case of form HxB, the term "OFF-state condition" is replaced by the term "OPEN position".

3.4.23

phase loss sensitive overload relay or release

multipole overload relay or release which operates in case of overload and also in case of loss of phase in accordance with specified requirements

3.4.24

under-current relay or release

measuring relay or release which operates automatically when the current through it is reduced below a predetermined value

3.4.25

under-voltage relay or release

measuring relay or release which operates automatically when the voltage applied to it is reduced below a predetermined value

3.4.26

stall sensitive electronic overload relay

electronic overload relay which operates when the current has not decreased below a predetermined value for a specific period of time during start-up or when the relay receives the input indicating there is no rotation of the motor after a predetermined time in accordance with specified requirements

NOTE Explanation of stall: rotor locked during start.

3.4.27

jam sensitive electronic overload relay

electronic overload relay which operates in the case of overload and also when the current has increased above a predetermined value for a specific period of time during run in accordance with specified requirements

NOTE Explanation of jam: high overload occurring after the completion of starting which causes the current to reach the locked rotor current value of the motor being controlled.

3.4.28

inhibit time

time-delay period during which the tripping function of the relay is inhibited (may be adjustable)

3.4.29

ON-time

period of time during which the controller is on-load

NOTE See the example in Figure F.1.

3.4.30

OFF-time

the period of time during which the controller is off-load

NOTE See the example in Figure F.1.

3.4.31

bypassed controller

equipment wherein the main circuit contacts of a mechanical switching device are connected in parallel with the main circuit terminals of a semiconductor switching device, and wherein the operating means of the two switching devices are co-ordinated

NOTE See Figure 1.

3.4.32

CO operation

breaking of the circuit by the SCPD resulting from closing the circuit by the equipment under test

3.4.33

O operation

breaking of the circuit by the SCPD resulting from closing the circuit on the equipment under test which is in the closed position

3.5 Terms and definitions concerning EMC definitions

NOTE For convenience and to avoid confusion, some of the key definitions from IEC 60050-161 are reproduced here. Further explanations are given in IEC 61000-2-1.

3.5.1

electromagnetic compatibility

EMC

ability of an equipment or system to function satisfactorily in its electromagnetic environment without introducing intolerable electromagnetic disturbances to anything in that environment

[IEC 60050-161:1990, 161-01-07]

3.5.2

electromagnetic emission

phenomenon by which electromagnetic energy emanates from a source

[IEC 60050-161:1990, 161-01-08]

3.5.3

electromagnetic disturbance

any electromagnetic phenomenon which may degrade the performance of a device, equipment or system, or adversely affect living or inert matter

NOTE An electromagnetic disturbance may be an electromagnetic noise, an unwanted signal, or a change in the propagation medium itself.

[IEC 60050-161:1990, 161-01-05]

3.5.4

radio (frequency) disturbance

electromagnetic disturbance having components in the radio frequency range

[IEC 60050-161:1990, 161-01-13]

3.5.5

radio frequency interference

RFI

degradation of the reception of a wanted signal caused by radio frequency disturbance

NOTE The English words "interference" and "disturbance" are often used indiscriminately. The expression 'radio-frequency interference' is also commonly applied to a radio-frequency disturbance or an unwanted signal.

[IEC 60050-161:1990, 161-01-14]

3.5.6

transient, adjective and noun

pertaining to or designating a phenomenon or a quantity which varies between two consecutive steady states during a time interval short compared with the time-scale of interest

[IEC 60050-161:1990, 161-02-01]

3.5.7

burst (of pulses or oscillations)

sequence of a limited number of distinct pulses or an oscillation of limited duration

[IEC 60050-161:1990, 161-02-07]

3.5.8

voltage surge

transient voltage wave propagating along a line or a circuit and characterized by a rapid increase followed by a slower decrease of the voltage

[IEC 60050-161:1990, 161-08-11]

3.6 Symbols and abbreviations

Symbol or abbreviation	Description	Definition or occurrence
A_f	Final ambient temperature	9.3.3.3.4
C_f	Final case temperature	9.3.3.3.4
EMC	Electromagnetic compatibility	3.5.1
EUT	Equipment under test	
I_c	Current made and broken	Table 13
I_e	Rated operational current	5.3.2.3
I_F	Leakage current after the blocking and commutating capability test	9.3.3.6.3
I_{init}	Initial test current	9.3.3.6.2
I_L	OFF-state leakage current	3.4.15
I_{LRP}	Prospective locked rotor current	3.4.10
I_O	Leakage current before the blocking and commutating capability test	9.3.3.6.3
I_{th}	Conventional free air thermal current	5.3.2.1
I_{the}	Conventional enclosed thermal current	5.3.2.2
I_u	Rated uninterrupted current	5.3.2.4
RFI	Radio frequency interference	3.5.5
SCPD	Short-circuit protective device	
U_c	Rated control circuit voltage	5.5
U_e	Rated operational voltage	5.3.1.1
U_i	Rated insulation voltage	5.3.1.2
U_{imp}	Rated impulse withstand voltage	5.3.1.3
U_r	Power frequency recovery voltage	Table 11
U_s	Rated control supply voltage	5.5

4 Classification

Subclause 5.2 gives all data which could be used as criteria for classification.

5 Characteristics of a.c. semiconductor motor controllers and starters

5.1 Summary of characteristics

The characteristics of controllers and starters shall be stated in the following terms, where such terms are applicable:

- type of equipment (5.2);
- rated and limiting values for main circuits (5.3);
- utilization category (5.4);
- control circuits (5.5);
- auxiliary circuits (5.6);
- types and characteristics of relays and releases (5.7);
- co-ordination with short-circuit protective devices (5.8).

5.2 Type of equipment

The following shall be stated:

5.2.1 Form of equipment

Forms of controllers and starters (see 3.3 and 3.4).

5.2.2 Number of poles

- Number of main poles
- Number of main poles where the operation is controlled by a semiconductor switching element

5.2.3 Kind of current

AC only.

5.2.4 Interrupting medium (air, vacuum, etc.)

Applicable only to mechanical switching devices of hybrid controllers and starters.

5.2.5 Operating conditions of the equipment

5.2.5.1 Method of operation

For example:

- symmetrically controlled controller (such as a semiconductor with fully controlled phases);
- non-symmetrically controlled controller (such as thyristors and diodes).

5.2.5.2 Method of control

For example:

- automatic (by pilot switch or sequence control);
- non-automatic (that is push-buttons);
- semi-automatic (that is partly automatic, partly non-automatic).

5.2.5.3 Method of connecting

For example (see Figure 2):

- motor in delta, thyristors in series with a winding;
- motor in star, thyristors in delta;
- motor in delta, thyristors connected between winding and supply.

5.3 Rated and limiting values for main circuits

The rated and limiting values established for controllers and starters shall be stated in accordance with 5.3.1 to 5.3.6, but it may not be necessary to establish all applicable values by tests.

5.3.1 Rated voltages

A controller or starter is defined by the following rated voltages.

5.3.1.1 Rated operational voltage (U_e)

Subclause 4.3.1.1 of IEC 60947-1:2007 applies with the following addition.

The rating of a.c. equipment shall include the number of phases except that the rating of equipment obviously intended for single-phase use only is not required to include the number of phases.

5.3.1.2 Rated insulation voltage (U_i)

Subclause 4.3.1.2 of IEC 60947-1:2007 applies.

5.3.1.3 Rated impulse withstand voltage (U_{imp})

Subclause 4.3.1.3 of IEC 60947-1:2007 applies.

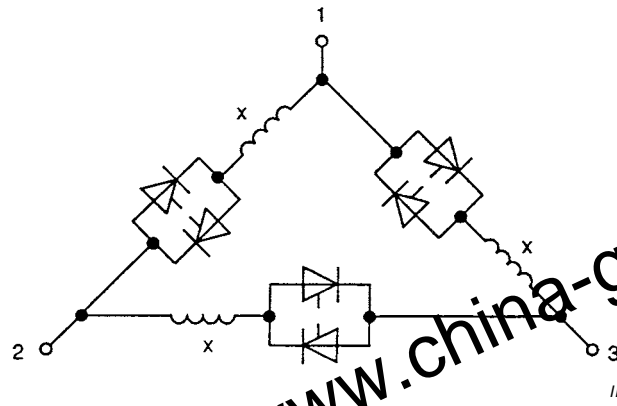

IEC 1735/99

Figure 2a – Motor in delta – Thyristors in series with a winding

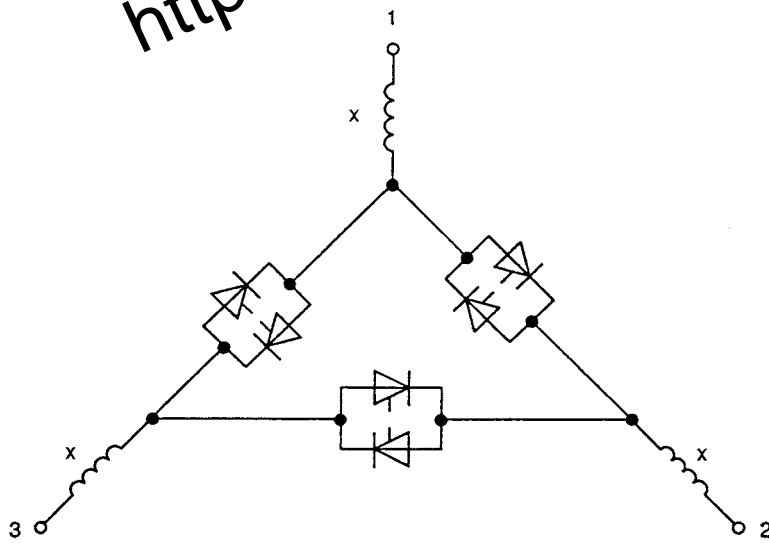

IEC 1736/99

Figure 2b – Motor in star – Thyristors in delta

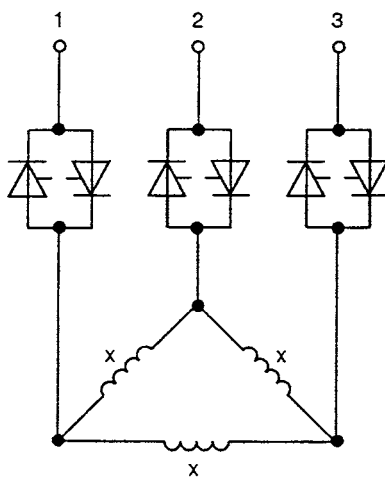

IEC 1737/99

Figure 2c – Motor in delta – Thyristors connected between winding and supply

Figure 2 – Connecting methods

5.3.2 Currents

A controller or starter is defined by the following currents:

5.3.2.1 Conventional free air thermal current (I_{th})

Subclause 4.3.2.1 of IEC 60947-1:2007 applies.

5.3.2.2 Conventional enclosed thermal current (I_{the})

Subclause 4.3.2.2 of IEC 60947-1:2007 applies.

5.3.2.3 Rated operational current (I_e)

The rated operational current of controllers and starters is the normal operating current when the device is in the FULL-ON state, and takes into account the rated operational voltage (see 5.3.1.1), the rated frequency (see 5.3.3), the rated duty (see 5.3.4), the utilization category (see 5.4), the overload characteristics (see 5.3.5), and the type of protective enclosure, if any.

5.3.2.4 Rated uninterrupted current (I_u)

Subclause 4.3.2.4:2007 of IEC 60947-1:2007 applies.

5.3.3 Rated frequency

Subclause 4.3.3:2007 of IEC 60947-1:2007 applies.

5.3.4 Rated duty

The rated duties considered as normal are as follows:

5.3.4.1 8 h duty

A duty in which the controller or starter remains in the FULL-ON state while carrying a steady current long enough for the equipment to reach thermal equilibrium, but not for more than 8 h, without interruption.

5.3.4.2 Uninterrupted duty

A duty in which the controller or starter remains in the FULL-ON state while carrying a steady current without interruption for periods of more than 8 h (weeks, months, or even years).

5.3.4.3 Intermittent periodic duty or intermittent duty

Subclause 4.3.4.3:2007 of IEC 60947-1:2007 applies, except that the first paragraph is changed as follows:

"A duty with on-load periods in which the controller or starter remains in the FULL-ON state, having a definite relation to off-load periods, both periods being too short to allow the equipment to reach thermal equilibrium."

5.3.4.4 Temporary duty

Duty in which the controller or starter remains in the FULL-ON state for periods of time insufficient to allow the equipment to reach thermal equilibrium, the current-carrying periods being separated by off-load periods of sufficient duration to restore equality of temperature with the cooling medium. Standard values of temporary duty are as follows:

30 s, 1 min, 3 min, 10 min, 30 min, 60 min and 90 min.

5.3.4.5 Periodic duty

Subclause 4.3.4.5 of IEC 60947-1:2007 applies.

5.3.4.6 Duty cycle values and symbols

For the purpose of this standard, the duty cycle is expressed by two symbols, F and S . These describe the duty, and also set the time that must be allowed for cooling.

F is the ratio of the on-load period to the total period expressed as a percentage.

The preferred values of F are as follows:

$F = 1\%, 5\%, 15\%, 25\%, 40\%, 50\%, 60\%, 70\%, 80\%, 90\%, 99\%$.

S is the number of operating cycles per hour. The preferred values of S are as follows:

$S = 1, 2, 3, 4, 5, 6, 10, 20, 30, 40, 50, 60$ operating cycles per hour.

NOTE Other values of F and/or S may be declared by the manufacturer.

5.3.5 Normal load and overload characteristics

Subclause 4.3.5 of IEC 60947-1:2007 applies, with the following additions.

5.3.5.1 Overload current profile

The overload current profile gives the current-time co-ordinates for the controlled overload current. It is expressed by two symbols, X and T_x .

X denotes the overload current as a multiple of I_e selected from the array of values in Table 9, and represents the maximum value of operating current due to starting, operating, or manoeuvring under overload conditions. $X = I_{LRP}/I_e$ when no current limit function is provided.

Deliberate overcurrents not exceeding 10 cycles (for example boost, kickstart, etc.), which may exceed the stated value of $X \times I_e$, are disregarded for the overload current profile.

T_x denotes the sum of duration times for the controlled overload currents during starting, operating, and manoeuvring. See Table 9.

For a starter, T_x is the minimum operating time allowed by the tolerances of the overload relay.

5.3.5.2 Operating capability

Operating capability represents the combined capabilities of

- current commutation and current carrying in the ON-state; and
- establishing and sustaining the OFF-state (blocking),
at full voltage under normal load and overload conditions in accordance with utilization category, overload current profile and specified duty cycles.

Operating capability is characterized by

- the rated operational voltage (see 5.3.1.1);
- the rated operational current (see 5.3.2.3);
- the rated duty (see 5.3.4);

- the overload current profile (see 5.3.5.1);
- the utilization category (see 5.4).

Requirements are given in 8.2.4.1.

5.3.5.3 Starting, stopping and manoeuvring characteristics

Typical service conditions for controllers and starters controlling squirrel cage and hermetic refrigeration motors are as follows:

5.3.5.3.1 Starting characteristics of squirrel cage and hermetic refrigeration motors

- a) One direction of rotation with the inclusion of phase-control capability to provide any combination of controlled acceleration to normal speed, controlled deceleration to standstill, or an occasional manoeuvre without de-energizing the controller (AC-53a, AC-58a).
- b) One direction of rotation with the inclusion of phase-control capability to provide controlled acceleration to normal speed. Controllers and starters are rated for intermittent duty only (AC-53b, AC-58b); for example after starting, the motor may be connected into a circuit that bypasses the power semiconductors.

Two directions of rotation may be accomplished by reversing the connections to the controller or motor by means that are beyond the scope of this standard, but are covered by the relevant product standard for the selected means.

Two directions of rotation may also be accomplished by phase reversing within the controller or starter. The requirements for this operation will vary with each application. Therefore, this is subject to agreement between manufacturer and user.

Due to the control capability of controllers and starters, the current during starting, stopping, and any manoeuvre will differ from the conventional values of the prospective locked rotor current listed in Table 11.

5.3.5.3.2 Starting characteristics of rheostatic rotor starters with controllers energizing the stator (AC-52a, AC-52b)

Starters can be used to provide reduced voltage excitation to the stator windings of a slip ring motor, and thereby reduce the number of switching steps required in the rotor circuit. For most applications, one or two starting steps are adequate depending upon load torque and inertia, and the severity of start required.

NOTE Starters and controllers covered by this standard are not intended for use in the rotor circuit and therefore, the rotor circuit must be controlled by traditional means. The relevant product standards for the rotor circuits of rheostatic rotor starters should apply.

5.3.6 Rated conditional short-circuit current

Subclause 4.3.6.4 of IEC 60947-1:2007 applies.

5.4 Utilization category

5.4.1 General

Subclause 4.4 of IEC 60947-1:2007 applies, with the following addition.

For controllers and starters, the utilization categories as given in Table 2 are considered standard. Any other type of utilization shall be based on agreement between manufacturer and user, but information given in the manufacturer's catalogue or tender may constitute such an agreement.

Each utilization category (see Table 2) is characterized by the values of the currents, voltages, power-factors and other data of Table 3, Table 9, Table 10 and Table 11, and by the test conditions specified in this standard.

The first digit of the utilization category identification designates a semiconductor switching device (for example within this standard a semiconductor motor controller or starter). The second digit designates a typical application. The a-suffix designates the capability of a controller to perform any of the functional possibilities listed in Table 3. The b-suffix designates the capability of a controller where it is restricted to performing a transition from an OFF-state to a starting function of duration T_x , and immediately returning to the OFF-state to comprise a duty cycle in accordance with the requirements of 8.2.4.1.

5.4.2 Assignment of ratings based on the results of tests

A designated controller or starter with a rating for one utilization category which has been verified by testing can be assigned other ratings without testing, provided that

- the rated operational current and voltage that are verified by testing shall not be less than the ratings that are to be assigned without testing;
- the utilization category and duty cycle requirements for the tested rating shall be equal to or more severe than the rating that is to be assigned without testing; the relative levels of severity are given in Table 3;
- the overload current profile for the tested rating shall be equal to or more severe than the rating that is to be assigned without testing, in accordance with the relative levels of severity in Table 3. Only values of X lower than the tested value of X may be assigned without testing.

Table 2 – Utilization categories

Utilization category	Typical application
AC-52a	Control of slip ring motor starters: 8 h duty with on-load currents for start, acceleration, run
AC-52b	Control of slip ring motor starters: intermittent duty
AC-53a	Control of squirrel cage motors: 8 h duty with on-load currents for start, acceleration, run
AC-53b	Control of squirrel cage motors: intermittent duty
AC-58a	Control of hermetic refrigerant compressor motors with automatic resetting of overload releases: 8 h duty with on-load currents for start, acceleration, run
AC-58b	Control of hermetic refrigerant compressor motors with automatic resetting of overload releases: intermittent duty
NOTE 1 The means of bypassing the semiconductor controller or starter may be integral with the controller/starter or installed separately. It also may be dependant or unrestricted as specified in 8.2.1.7 and 8.2.1.8.	
NOTE 2 A hermetic refrigerant compressor motor is a combination consisting of a compressor and motor, both of which are enclosed in the same housing, with no external shaft or shaft seals, the motor operating in the refrigerant.	

Table 3 – Relative levels of severity

Severity level	Utilization category	Overload current profile ($X-T_x$)	Time related requirement
Most severe	AC-52a AC-53a AC-58a	Highest value of $(X I_e)^2 \times T_x$ (Note 1)	Highest value of $F \times S$ (Note 2)
	AC-52b AC-53b AC-58b	Highest value of $(X I_e)^2 \times T_x$ (Note 1)	Lowest value of OFF-time (Note 3)
<p>When the highest value of $(X I_e)^2 \times T_x$ occurs at more than one value of $X I_e$, then the highest value of $X I_e$ shall apply.</p> <p>When the highest value of $F \times S$ occurs at more than one value of S, then the highest value of S shall apply.</p> <p>When the highest value of $(X I_e)^2 \times T_x$ occurs at more than one value of OFF-time, then the lowest value of OFF-time shall apply.</p>			

5.5 Control circuits

Subclause 4.5.1 of IEC 60947-1:2007 applies, with the following additions:

Refer to Annex G for examples and illustrations. The characteristics of electronic control circuits are as follows:

- kind of current;
- power consumption;
- rated frequency (or d.c.);
- rated control circuit voltage, U_c (nature: a.c./d.c.);
- rated control supply voltage, U_s (nature: a.c./d.c.);
- nature of control circuit devices (contacts, sensors).

NOTE A distinction is made between control circuit voltage, U_c , which is the controlling input signal, and control supply voltage, U_s , which is the voltage applied to energize the power supply terminals of the control circuit equipment and may be different from U_c , due to built-in transformers, rectifiers, resistors, etc.

5.6 Auxiliary circuits

Subclause 4.6 of IEC 60947-1:2007 applies, with the following additions:

Electronic auxiliary circuits perform useful functions (for example monitoring, data acquisition, etc.) that are not necessarily relevant to the direct task of governing the intended performance characteristics.

Under normal conditions, auxiliary circuits are characterized in the same way as control circuits, and are subject to the same kinds of requirements. If the auxiliary functions include unusual performance features, the manufacturer should be consulted to define the critical characteristics.

Digital inputs and/or digital outputs contained in controllers and motor-starters, and intended to be compatible with PLCs, shall fulfil the requirements of Annex S of IEC 60947-1:2007.

5.7 Characteristics of relays and releases (overload relays)

NOTE In the remainder of this standard, the words "overload relay" will be taken to apply equally to an overload relay or an overload release, as appropriate.

5.7.1 Summary of characteristics

The characteristics of relays and releases shall be stated in the following terms, whenever applicable:

- types of relay or release (see 5.7.2);
- characteristic values (see 5.7.3);
- designation and current settings of overload relays (see 5.7.4);
- time-current characteristics of overload relays (see 5.7.5);
- influence of ambient air temperature (see 5.7.6).

5.7.2 Types of relay or release

- a) Under-voltage and under-current opening relay or release.
- b) Overload time-delay relay, the time-lag of which is
 - 1) substantially independent of previous load;
 - 2) dependent on previous load;
 - 3) dependent on previous load and also sensitive to phase loss.
- c) Instantaneous over-current relay or release (for example jam sensitive).
- d) Other relays or releases (for example control relay associated with devices for the thermal protection of the starter).
- e) Stall relay or release.

5.7.3 Characteristic values

- a) Release with shunt coil, under-voltage (under-current), over-voltage (instantaneous over-current), current or voltage asymmetry and phase reversal opening relay or release:
 - rated voltage (current);
 - rated frequency;
 - operating voltage (current);
 - operating time (when applicable);
 - inhibit time (when applicable).
- b) Overload relay:
 - designation and current settings (see 5.7.4);
 - rated frequency, when necessary (for example in the case of a current transformer operated overload relay);
 - time-current characteristics (or range of characteristics), when necessary;
 - trip class according to classification in Table 4, or the value of the maximum tripping time, in seconds, under the conditions specified in 8.2.1.5.1.1.1 and Table 5, column *D*, when this time exceeds 30 s;
 - nature of the relay: thermal, electronic or electronic without thermal memory;
electronic relay without thermal memory shall be marked ~~Thm~~ ;
 - nature of the reset: manual or automatic,
 - tripping time of overload relays class 10A where higher than 2 min at 0 °C or below (see 8.2.1.5.1.1.1, item c).
- c) Release with residual current sensing relay:
 - rated current;

- operating current;
- operating time or time-current characteristic according to Table K.1;
- inhibit time (when applicable);
- type designation (see Annex K).

Table 4 – Trip classes of overload relays

Trip class	Tripping time T_p under the conditions specified in 8.2.1.5.1.1.1 and Table 5, column D ^a	Tripping time T_p under the conditions specified in 8.2.1.5.1.1.1 and Table 5, column D for tighter tolerances (tolerance band E) ^a
2	–	$T_p \leq 2$
3	–	$2 < T_p \leq 3$
5	$0,5 < T_p \leq 5$	$3 < T_p \leq 5$
10A	$2 < T_p \leq 10$	–
10	$4 < T_p \leq 10$	$5 < T_p \leq 10$
20	$6 < T_p \leq 20$	$10 < T_p \leq 20$
30	$9 < T_p \leq 30$	$20 < T_p \leq 30$
40	–	$30 < T_p \leq 40$
NOTE 1 Depending on the nature of the relay, the tripping conditions are given in 8.2.1.5.		
NOTE 2 The lower limiting values of T_p are selected to allow for differing heater characteristics and manufacturing tolerances.		
^a The manufacturer shall add the letter E to trip classes to indicate compliance with the band E.		

5.7.4 Designation and current settings of overload relays

Overload relays are designated by their current setting (or the upper and lower limits of the current setting range, if adjustable) and their trip class.

The current setting (or current setting range) shall be marked on the relays.

However, if the current setting is influenced by the conditions of use or other factors which cannot readily be marked on the relay, then the relay or any interchangeable parts thereof (for example heaters, operating coils or current transformers) shall carry a number or an identifying mark which makes it possible to obtain the relevant information from the manufacturer or his catalogue or, preferably, from data furnished with the starter.

In the case of current transformer operated overload relays, the marking may refer either to the primary current of the current transformer through which they are supplied or to the current setting of the overload relays. In either case, the ratio of the current transformer shall be stated.

5.7.5 Time-current characteristics of overload relays

Typical time-current characteristics shall be given in the form of curves supplied by the manufacturer. These curves shall indicate how the tripping time, starting from the cold state (see 5.7.6), varies with the current up to a value of at least maximum ($X \times I_e$) value. The manufacturer shall be prepared to indicate, by suitable means, the general tolerances

applicable to these curves and the conductor cross-sections used for establishing these curves (see 9.3.3.6.5, item c)).

NOTE It is recommended that the current be plotted as abscissae and the time as ordinates, using logarithmic scales. It is recommended that the current be plotted as multiples of the setting current and the time in seconds on the standard graph sheet detailed in IEC 60269-1.

5.7.6 Influence of ambient air temperature

The time-current characteristics (see 5.7.5) refer to a stated value of ambient air temperature, and are based on no previous loading of the overload relay (i.e. from an initial cold state). This value of the ambient air temperature shall be clearly given on the time curves; the preferred values are +20 °C or +40 °C.

The overload relays shall be able to operate within the ambient air temperature range of 0 °C to +40 °C, and the manufacturer shall be prepared to state the effect of variation in ambient air temperature on the characteristics of overload relays.

5.8 Co-ordination with short-circuit protective devices (SCPD)

Controllers and starters are characterized by the type, ratings, and characteristics of the SCPD to be used to provide overcurrent discrimination between starter and SCPD, and adequate protection of controllers and starters against short-circuit currents.

Requirements are given in 8.2.5 of this standard and in 4.8 of IEC 60947-1:2007.

6 Product information

6.1 Nature of information

The following information shall be given by the manufacturer:

Identification

- a) the manufacturer's name or trademark;
- b) type designation or serial number;
- c) number of this standard;

Characteristics, basic rated values and utilization

- d) rated operational voltages (see 5.3.1.1);
- e) rated operational currents, corresponding utilization category (5.4), overload current profile (5.3.5.1), and duty cycle (5.3.4.6) or OFF-time, comprising the rating index;
 - The prescribed format for AC-52a, AC-53a, AC-58a is shown by these examples:
100 A: AC-53a: 6-6: 60-1
This indicates 100 A current rating for general applications with squirrel cage motors. The device can accommodate 600 A for 6 s; 60 % on-load factor; one standard operating cycle per hour.
 - The prescribed format for AC-52b, AC-53b, AC-58b is shown by the example:
100 A: AC-53b: 3-52: 1 440
This indicates 100 A current rating for starting duty only. The device can accommodate 300 A for 52 s; the OFF-time must not be less than 1440 s before any subsequent start may be initiated.
- f) either the value of the rated frequency 50/60 Hz, or other rated frequencies for example 16 2/3 Hz, 400 Hz;

- g) indication of the rated duties as applicable (5.3.4.3);
- h) form designation (for example form 1, or form H1A, see Table 1);

Safety and installation

- i) rated insulation voltage (5.3.1.2);
- j) rated impulse withstand voltage (5.3.1.3);
- k) IP code, in case of an enclosed equipment (8.1.11);
- l) pollution degree (7.1.3.2);
- m) rated conditional short-circuit current and type of co-ordination of the controller or starter, and the type, current rating and characteristics of the associated SCPD (see 5.8);

Control circuits

- n) rated control circuit voltage U_c , nature of current and rated frequency, and, if necessary, rated control supply voltage U_s , nature of current and rated frequency, and any other information (for example impedance matching requirements) necessary to ensure satisfactory operation of the control circuits (see Annex G for examples of control circuit configurations);

Auxiliary circuits

- o) nature and ratings of auxiliary circuits (5.6);

Overload relays and releases

- p) characteristics according to 5.7.2, 5.7.5 and 5.7.6;
- q) characteristics according to 5.7.3 and 5.7.4;

EMC emission and immunity levels

- r) the equipment class and the specific requirements necessary to maintain compliance (see 8.3.2);
- s) the immunity levels attained and the specific requirements necessary to maintain compliance (see 8.3.3).

6.2 Marking

Subclause 5.2 of IEC 60947-1:2007 applies to controllers and starters, with the following additions:

Data under c) to s) in 6.1 shall be included on the nameplate, or on the equipment, or in the manufacturer's published literature.

Data under items c), k) and q) in 6.1 shall be marked on the equipment; time-current characteristics (or range of characteristics) may be provided in the manufacturer's published literature.

6.3 Instructions for installation, operation, and maintenance

Subclause 5.3 of IEC 60947-1:2007 applies, with the following addition.

For products complying with this standard, the following are specific items to be considered

- in the event of a short-circuit;
- in case of switching devices in bypassed controllers suitable only for restricted use (see 8.2.1.9);
- in the event of temperature rise above 50 K of the metallic radiator surface of the device.

The manufacturer of a starter incorporating an overload relay with a means allowing an automatic restart shall provide, with the starter, any necessary information to alert the user to the possibility of an automatic restart.

7 Normal service, mounting and transport conditions

Clause 6 of IEC 60947-1:2007 applies, with the following exceptions:

7.1 Normal service conditions

Subclause 6.1 of IEC 60947-1:2007 applies, with the following exceptions:

7.1.1 Ambient air temperature

Subclause 6.1.1 of IEC 60947-1:2007 applies with the exception that all references to $-5\text{ }^{\circ}\text{C}$ are replaced by $0\text{ }^{\circ}\text{C}$.

7.1.2 Altitude

The altitude of the site of installation does not exceed 1 000 m.

NOTE For equipment to be used at higher altitudes, it is necessary to take into account the reduction of the dielectric strength, and the cooling effect of the air. Electrical equipment intended to operate in these conditions are designed or used in accordance with an agreement between manufacturer and user.

7.1.3 Atmospheric conditions

7.1.3.1 Humidity

Subclause 6.1.3.1 of IEC 60947-1:2007 applies.

7.1.3.2 Degrees of pollution

Unless otherwise stated by the manufacturer, controllers and starters are intended for use in pollution degree 3 environmental conditions, as defined in 6.1.3.2 of IEC 60947-1:2007. However, other pollution degrees may be considered to apply, depending upon the micro-environment.

7.1.4 Shock and vibrations

Subclause 6.1.4 of IEC 60947-1:2007 applies.

7.2 Conditions during transport and storage

Subclause 6.2 of IEC 60947-1:2007 applies.

7.3 Mounting

Subclause 6.3 of IEC 60947-1:2007 applies, and for EMC considerations, see 8.3 and 9.3.5 below.

7.4 Electrical system disturbances and influences

For EMC considerations, see 8.3 and 9.3.5.

8 Constructional and performance requirements

8.1 Constructional requirements

8.1.1 General

Subclause 7.1.1 of IEC 60947-1:2007 applies.

8.1.2 Materials

8.1.2.1 General materials requirements

Subclause 7.1.2.1 of IEC 60947-1:2007 applies.

8.1.2.2 Glow wire testing

Subclause 7.1.2.2 of IEC 60947-1:2007 applies with the following addition.

When tests on the equipment or on sections taken from the equipment are used, parts of insulating materials necessary to retain current-carrying parts in position shall conform to the glow-wire tests of 8.2.1.1.1 in IEC 60947-1:2007 at a test temperature of 850 °C.

8.1.2.3 Test based on flammability category

Subclause 7.1.2.3 of IEC 60947-1:2007 applies.

8.1.3 Current-carrying parts and their connections

Subclause 7.1.3 of IEC 60947-1:2007 applies.

8.1.4 Clearances and creepage distances

Subclause 7.1.4 of IEC 60947-1:2007 applies with the following note.

NOTE The nature of a semiconductor makes it unsuitable for use for isolation purposes.

8.1.5 Actuator

Vacant.

8.1.6 Indication of the contact position

Vacant.

8.1.7 Additional requirements for equipment suitable for isolation

Vacant.

8.1.8 Terminals

Subclause 7.1.8 of IEC 60947-1:2007 applies with, however, the following additional requirements.

8.1.8.4 Terminal identification and marking

Subclause 7.1.8.4 of IEC 60947-1:2007 applies with additional requirements as given in Annex A.

8.1.9 Additional requirements for equipment provided with a neutral pole

Vacant.

8.1.10 Provisions for protective earthing

Subclause 7.1.10 of IEC 60947-1:2007 applies.

8.1.11 Enclosures for equipment

Subclause 7.1.11 of IEC 60947-1:2007 applies.

8.1.12 Degrees of protection of enclosure equipment

Subclause 7.1.12 of IEC 60947-1:2007 applies.

8.1.13 Conduit pull-out, torque and bending with metallic conduits

Subclause 7.1.13 of IEC 60947-1:2007 applies.

8.2 Performance requirements

8.2.1 Operating conditions

8.2.1.1 General

Auxiliary devices used in controllers and starters shall be operated in accordance with the manufacturer's instructions and their relevant product standard.

8.2.1.1.1 Controllers and starters shall be so constructed that they

- a) are trip free;
- b) can be caused to return to the OPEN or OFF-state by the means provided when running and at any time during the starting sequence or when performing any manoeuvre.

Compliance is verified in accordance with 9.3.3.6.3.

8.2.1.1.2 Controllers and starters shall not malfunction due to mechanical shock or electromagnetic interference caused by operation of its internal devices.

Compliance is verified in accordance with 9.3.3.6.3.

8.2.1.1.3 The moving contacts of the series mechanical switching device in hybrid controllers and starters shall be so mechanically coupled that all poles make and break substantially together, whether operated manually or automatically.

8.2.1.2 Limits of operation of controllers and starters

Controllers or starters shall function satisfactorily at any voltage between 85 % and 110 % of their rated operational voltage, U_e , and rated control supply voltage, U_s , when tested according to 9.3.3.6.3. Where a range is declared, 85 % shall apply to the lower value, and 110 % to the higher.

8.2.1.3 Limits of operation of undervoltage relays and releases

Vacant

8.2.1.4 Limits of operation of shunt coil operated releases (shunt trip)

Vacant

8.2.1.5 Limits of operation of current sensing relays and releases

8.2.1.5.1 Relays and releases in starters

8.2.1.5.1.1 Limits of operation of time-delay overload relays when all poles are energized

8.2.1.5.1.1.1 General tripping requirements of overload relays

NOTE 1 The thermal protection of motors in the presence of harmonics in the supply voltage is under consideration.

The relays shall comply with the requirements of Table 5 when tested as follows:

- a) with the overload relay or starter in its enclosure, if normally fitted, and at *A* times the current setting, tripping shall not occur in less than 2 h starting from the cold state, at the value of reference ambient air temperature stated in Table 5. However, when the overload relay terminals have reached thermal equilibrium at the test current in less than 2 h, the test duration can be the time needed to reach such thermal equilibrium;
- b) when the current is subsequently raised to *B* times the current setting, tripping shall occur in less than 2 h;
- c) for class 2, 3, 5 and 10 A overload relays energized at *C* times the current setting, tripping shall occur in less than 2 min starting from thermal equilibrium, at the current setting, in accordance with 9.3.3 of IEC 60034-1:2010;

NOTE 2 Subclause 9.3.3 of IEC 60034-1:2010 states: "Polyphase motors having rated outputs not exceeding 315 kW and rated voltages not exceeding 1 kV shall be capable of withstanding a current equal to 1,5 times the rated current for not less than 2 min."

- d) for class 10, 20, 30 and 40 overload relays energized at *C* times the current setting, tripping shall occur in less than 4 min, 8 min, 12 min or 16 min respectively, starting from thermal equilibrium, at the current setting;
- e) at *D* times the current setting, tripping shall occur within the limits given in Table 4 for the appropriate trip class and tolerance band, starting from the cold state.

In the case of overload relays having a current setting range, the limits of operation shall apply when the relay is carrying the current associated with the maximum setting and also when the relay is carrying the current associated with the minimum setting.

For non-compensated overload relays, the current multiple/ambient temperature characteristic shall not be greater than 1,2 %/K.

NOTE 3 1,2 %/K is the derating characteristic of PVC-insulated conductors.

An overload relay is regarded as compensated if it complies with the relevant requirements of Table 5 at +20 °C and is within the limits shown in Table 20 at other temperatures.

Table 5 – Limits of operation of time-delay overload relays when energized on all poles

Type of overload relay	Multiples of current setting				Ambient air temperature values
	A	B	C	D	
Thermal type not compensated for ambient air temperature variations	1,0	1,2 ^b	1,5	7,2	+40 °C
Thermal type compensated for ambient air temperature variations	c	c	–	–	Less than 0 °C ^d
	1,05	1,3	1,5	–	0 °C

Type of overload relay	Multiples of current setting				Ambient air temperature values
	A	B	C	D	
		1,05	1,2 ^b	1,5	7,2
	1,0	1,2 ^b	1,5	–	+40 °C
	c	c	–	–	More than +40 °C ^d
Electronic type ^a	1,05	1,2 ^b	1,5	7,2	0 °C, +20 °C and +40 °C

^a This tests A, B and D shall only be done at 20 °C.
^b If specified by the manufacturer the tripping current could be different from 120 % but shall not exceed 125 %. In this case the test current value shall be equal to this tripping current value. In this case the tripping current value shall be marked on the product.
^c Multiples of current setting should be declared by the manufacturers.
^d See 9.3.3.6.5 for test outside the range 0 °C to +40 °C.

8.2.1.5.1.1.2 Thermal memory test verification

Unless the manufacturer has specified that the device does not contain thermal memory, electronic overload relays shall fulfil the following requirements (see Figure 3):

- apply a current equal to I_e until the device has reached the thermal equilibrium;
- interrupt the current for a duration of $2 \times T_p$ (see Table 4) with a relative tolerance of $\pm 10\%$ (where T_p is the time measured at the D current according to Table 5);
- apply a current equal to $7,2 \times I_e$;
- the relay shall trip within 50 % of the time T_p .

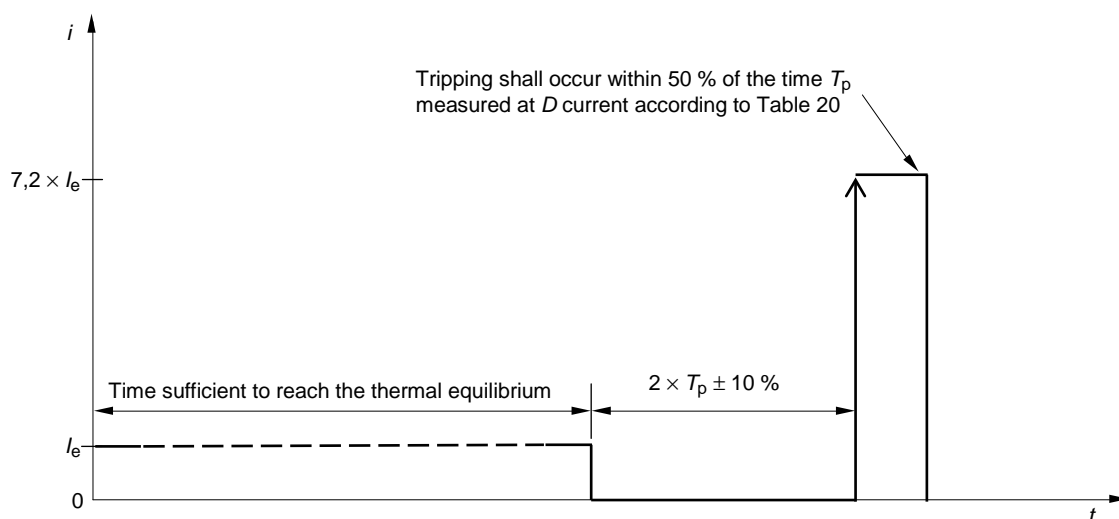

IEC 2199/06

Figure 3 – Thermal memory test

8.2.1.5.1.2 Limits of operation of three-pole time-delay overload relays energized on two poles

With reference to Table 6:

The overload relay or starter shall be tested in its enclosure if normally fitted. With the relay energized on three poles, at A times the current setting, tripping shall not occur in less than 2 h, starting from the cold state, at the value of the ambient air temperature stated in Table 6.

Moreover, when the value of the current flowing in two poles (in phase loss sensitive relays, those carrying the higher current) is increased to B times the current setting, and the third pole de-energized, tripping shall occur in less than 2 h.

The values shall apply to all combinations of poles.

In the case of overload relays having an adjustable current setting, the characteristics shall apply both when the relay is carrying the current associated with the maximum setting and when the relay is carrying the current associated with the minimum setting.

Table 6 – Limits of operation of three-pole time-delay overload relays when energized on two poles only

Type of overload relay	Multiples of current setting		Reference ambient air temperature
	A	B	
Thermal, compensated for ambient air temperature variations or electronic Not phase loss sensitive	3 poles 1,0	2 poles 1,32 1 pole 0	+20 °C
Thermal, not compensated for ambient air temperature variations Not phase loss sensitive	3 poles 1,0	2 poles 1,25 1 pole 0	+40 °C
Thermal, compensated for ambient air temperature variations or electronic Phase loss sensitive	2 poles 1,0 1 pole 0,9	2 poles 1,15 1 pole 0	+20 °C

8.2.1.5.2 Relays and releases associated with controllers

Relays and releases to be associated with a controller to provide protection for the motor shall operate within a time T_x at a current $X \times I_e$, where X and T_x are the values given by the declared rating index. In the case of more than one declared rating index, X and T_x are the values corresponding to the rating index giving the highest product $(XI_e)^2 \times T_x$.

8.2.1.5.3 Limits of operation of under-current relays

An under-current relay or release, when associated with a switching device, shall operate to open the switching device within 90 % to 110 % of the set time when the current during operation is below 0,9 times the under-current setting in all poles.

8.2.1.5.4 Limits of operation of stall relays

A stall relay, when associated with a switching device, shall operate to open the switching device within 80 % to 120 % of the set time (stall inhibit time) or within the accuracy specified by the manufacturer, when

- a) for current sensing relays, the current is 20 % higher than the set stall current value;

EXAMPLE Set current of the stall relay: 100 A; set time: 6 s; time setting accuracy: ± 10 %. The relay shall trip within 5,4 s and 6,6 s when the current is equal to or greater than $100 \text{ A} \times 1,2 = 120 \text{ A}$.

- b) for rotation sensing relays, an input signal indicating no motor rotation exists.

8.2.1.5.5 Limits of operation of jam relays and releases

A jam relay or release, when associated with a switching device, shall operate to open the switching device within 80 % to 120 % of the set time (jam inhibit time) or within the accuracy specified by the manufacturer, when the current is above 1,2 times the set current value of the jam relay, during running after completion of the starting.

8.2.1.6 Type tested components in bypassed controllers

8.2.1.6.1 Switching devices which meet the requirements of their own relevant product standard shall be considered as partially type tested devices subject to the following additional requirements:

- a) the temperature rises of mechanical switching devices shall comply with 8.2.1.6.2;
- b) the making and breaking capacity of mechanical switching devices shall comply with 8.2.4.2;
- c) semiconductor switching devices shall comply with 8.2.1.6.2 of utilization category AC-53b.

8.2.1.6.2 For the purpose of setting requirements for bypassed controllers, switching devices which meet all of the requirements of 8.2.1.6.1, before they are installed, shall be identified as type tested components suitable for unrestricted use in a bypassed controller (see Annex J).

8.2.1.7 Dependent components in bypassed controllers

For the purpose of setting requirements for bypassed controllers, switching devices which do not meet all of the requirements of 8.2.1.6.1, before they are installed, shall be identified as dependent components suitable only for restricted use in a bypassed controller (see Annex J).

8.2.1.8 Unrestricted use of switching devices in bypassed controllers

When both the mechanical switching device and the semiconductor switching device are identified as type tested components, these devices shall be arranged and connected to comply with the assigned rating, duty and the end use intended by the manufacturer. There shall be no further restrictions.

8.2.1.9 Restricted use of switching devices in bypassed controllers

When either one or both switching devices are identified as dependent components, the switching devices shall comply with the following:

- a) the switching devices shall be combined, rated and tested as a unit;
- b) the switching devices shall be interlocked, by any combination of electrical, electronic and mechanical means, such that the mechanical switching contacts shall not be required to make or break overload currents without direct intervention by the semiconductor switching device;
- c) the semiconductor switching device shall be enabled to take over the control of the current flowing in the main circuit whenever it is necessary to make or break overload currents.

8.2.2 Temperature rise

The requirements of 7.2.2 of IEC 60947-1:2007 apply to controllers and starters in a clean, new condition.

NOTE Contact resistance due to oxidation may impact the temperature rise test at test voltages below 100 V. In the case of conducting the test at a voltage below 100 V, mechanical switching devices may have the contacts cleaned either by any nonabrasive method or by carrying out operating cycles with or without load several times prior to initiating the test at any voltage.

Temperature rise deviations on the metallic radiator surface of semiconductor devices are permitted: 50 K in the case where they need not be touched during normal operation.

If the limit of 50 K is exceeded, guarding and location to prevent danger is the responsibility of the installer. The manufacturer shall provide a suitable warning (for example symbol IEC 60417-5041 (2002-10)) in accordance with 6.3.

8.2.2.1 Terminal

Subclause 7.2.2.1 of IEC 60947-1:2007 applies.

8.2.2.2 Accessible parts

Subclause 7.2.2.2 of IEC 60947-1:2007 applies.

8.2.2.3 Ambient air temperature

Subclause 7.2.2.3 of IEC 60947-1:2007 applies.

8.2.2.4 Main circuit

8.2.2.4.1 General

The main circuit of a controller or starter, which carries current in the full-on state, including the over-current releases which may be associated with it, shall be capable of carrying the current I_e without the temperature rises exceeding the limits specified in 7.2.2.1 of IEC 60947-1:2007 when tested in accordance with 9.3.3.3.4:

- for a controller or starter intended for 8 h duty: its conventional thermal current (see 5.3.2.1 and/or 5.3.2.2);
- for a controller or starter intended for uninterrupted duty, intermittent or temporary duty: the relevant rated operational current (5.3.2.3).

8.2.2.4.2 Series mechanical switching devices for hybrid controllers

For hybrid controllers, the temperature rise of the components in series with the main circuit shall be verified by the procedures given in 9.3.3.3.4 and 9.3.3.6.1 (see Table 16).

8.2.2.4.3 Parallel mechanical switching devices for bypassed controllers

- a) Devices identified as type tested components (see 8.2.1.6) shall be capable of carrying the current I_e without the temperature rises exceeding the limits specified in 7.2.2.1 of IEC 60947-1:2007.
- b) For devices identified as dependent components (see 8.2.1.7), the temperature rise shall be verified by the procedures given in 9.3.3.3.4 and 9.3.3.6.1 (including Table 10 and Table 16). The device shall be tested as an integral part of a unit where the prescribed on-load periods for the two switching devices (Table 10) shall be determined by a sequence of operations which is the same as intended in normal service.

8.2.2.4.4 Semiconductor devices connected in the main circuit

The temperature rise of the semiconductor devices connected in the main circuit shall be verified by the procedures given in 9.3.3.3.4 and 9.3.3.6.1 (thermal stability test).

8.2.2.5 Control circuits

Subclause 7.2.2.5 of IEC 60947-1:2007 applies.

8.2.2.6 Windings of coils and electromagnets

8.2.2.6.1 Uninterrupted and 8 h duty windings

With the maximum value of current flowing through the bypass circuit, the windings of the coils, including those of electrically operated valves of electropneumatic contactors or starters, shall withstand under continuous load and at rated frequency, if applicable, their maximum rated control supply voltage without the temperature rise exceeding the limits specified in Table 7 of this standard and 7.2.2.2 of IEC 60947-1:2007.

NOTE The temperature rise limits given in Table 7 of this standard and in 7.2.2.2 of IEC 60947-1:2007 are applicable only if the ambient air temperature remains within the limits of 0 °C to +40 °C.

8.2.2.6.2 Intermittent duty windings

With no current flowing through the bypass circuit, the windings of the coils shall withstand, at the rated frequency if applicable, their maximum rated control supply voltage applied as detailed in Table 8 according to their intermittent duty class, without the temperature rise exceeding the limits specified in Table 7 of this standard and 7.2.2.2 of IEC 60947-1:2007.

NOTE The temperature rise limits given in Table 7 of this standard and in 7.2.2.2 of IEC 60947-1:2007 are applicable only if the ambient air temperature remains within the limits of 0 °C to +40 °C.

8.2.2.6.3 Specially rated (temporarily or periodic duty) windings

Specially rated windings shall be tested under operating conditions corresponding to the most severe duty for which they are intended and their ratings shall be stated by the manufacturer.

NOTE Specially rated windings may include coils of starters which are energized during the starting period only, trip coils of latched contactors and certain magnetic valve coils for inter-locking pneumatic contactors or starters.

Table 7 – Temperature rise limits for insulated coils in air and in oil

Class of insulating material (according to IEC 60085)	Temperature rise limit (measured by resistance variation)	
	K	
	Coils in air	Coils in oil
A	85	60
E	100	60
B	110	60
F	135	–
H	160	–

Table 8 – Intermittent duty test cycle data

Intermittent duty class		One close-open operating cycle every	Interval of time during which the supply to the control coil is maintained
Contactors	Starters		
1	1	3 600 s	On time should correspond to the on-load factor specified by the manufacturer
3	3	1 200 s	
12	12	300 s	
30	30	120 s	
120		30 s	
300		12 s	
1 200		3 s	

8.2.2.7 Auxiliary circuits

Subclause 7.2.2.7 of IEC 60947-1:2007 applies.

8.2.2.8 Other parts

Subclause 7.2.2.8 of IEC 60947-1:2007 applies, replacing words “plastics and insulating materials” with “insulating parts”.

8.2.3 Dielectric properties

The following requirements are based on the principles of the IEC 60664 series and provide the means of achieving coordination of insulation of equipment with the conditions within the installation.

The equipment shall be capable of withstanding

- the rated impulse withstand voltage (see 5.3.1.3) in accordance with the overvoltage category given in Annex H of IEC 60947-1:2007;
- the impulse withstand voltage across the contact gaps of devices suitable for isolation as given in Table 14 of IEC 60947-1:2007;
- the power-frequency withstand voltage.

NOTE 1 A direct voltage may be used instead, provided its value is not less than the projected alternating test voltage crest value.

NOTE 2 The correlation between the nominal voltage of the supply system and the rated impulse withstand voltage of the equipment is given in Annex H of IEC 60947-1:2007.

The rated impulse withstand voltage for a given rated operational voltage (see Notes 1 and 2 of 4.3.1.1 of IEC 60947-1:2007) shall be not less than that corresponding in Annex H of IEC 60947-1:2007 to the nominal voltage of the supply system of the circuit at the point where the equipment is to be used, and the appropriate overvoltage category.

The requirements of this subclause shall be verified by the tests of 9.3.3.4.

8.2.3.1 Impulse withstand voltage

1) Main circuit

Subclause 7.2.3.1 1) of IEC 60947-1:2007 applies.

2) Auxiliary and control circuits

Subclause 7.2.3.1 2) of IEC 60947-1:2007 applies with 2) a) modified as follows:

- a) For auxiliary and control circuits which operate directly from the main circuit at the rated operational voltage, clearances from live parts to parts intended to be earthed and between poles shall withstand the test voltage given in Table 12 of IEC 60947-1:2007 appropriate to the rated impulse withstand voltage.

NOTE Solid insulation of equipment associated with clearances should be subjected to the impulse voltage.

8.2.3.2 Power-frequency withstand voltage of the main, auxiliary and control circuits

Subclause 7.2.3.2 of IEC 60947-1:2007 applies.

8.2.3.3 Clearances

Subclause 7.2.3.3 of IEC 60947-1:2007 applies.

8.2.3.4 Creepage distances

Subclause 7.2.3.4 of IEC 60947-1:2007 applies.

8.2.3.5 Solid insulation

Subclause 7.2.3.5 of IEC 60947-1:2007 applies.

8.2.3.6 Spacing between separate circuits

Subclause 7.2.3.6 of IEC 60947-1:2007 applies.

8.2.4 Normal load and overload performance requirements

Requirements concerning normal load and overload characteristics according to 5.3.5 are given in 8.2.4.1 and 8.2.4.2.

8.2.4.1 Operating capability requirements

Controllers and starters shall be required to establish an ON-state, to commute, to carry designated levels of overload currents, and to establish and sustain an OFF-state condition without failure or any type of damage when tested according to 9.3.3.6.

For controllers that are designated for utilization categories AC-52a, AC-53a, AC-58a, values of T_x corresponding to X values shall not be less than those given in Table 9. For corresponding starters, T_x shall be the maximum tripping time of its overload relay in hot state declared by the manufacturer.

Controllers and starters that are designated for utilization categories AC-52b, AC-53b and AC-58b may be designated for those applications where long accelerating times are required. It must be understood that the maximum thermal capacity of the controller may be depleted fully during the on-load period. Therefore, a suitable off-load period (for example by bypass means) shall be provided for the controller immediately after the starting time has expired. The values of T_x corresponding to X values shall not be less than those given in Table 9. For corresponding starters, T_x shall be the maximum tripping time of its appropriate overload relay.

Where no current-limit function exists, or does not exist in the FULL-ON state, then $X \times I_e = I_{LRP}$. In a locked rotor situation arising while the motor has been running at normal speed, the controller or starter shall be permitted to establish an OFF-state condition in shorter times than those given, provided it is equipped with a suitable overload protection.

Ratings shall be verified under the conditions stated in Table 10 and Table 11 of this standard, and in the relevant parts of 8.3.3.5.2, 8.3.3.5.3, and 8.3.3.5.4 of IEC 60947-1:2007.

Where $X \times I_e$ is greater than 1 000 A, verification of the overload capability shall be subject to agreement between manufacturer and user (for example by computer modelling).

In Table 10 and Table 11, the duty cycle for utilization categories AC-52a, AC-53a, AC-58a (F-S = 60-1), and the off-time for utilization categories AC-52b, AC-53b, AC-58b (off-time = 1 440 s), are the least severe requirements for one start per hour. The manufacturer may claim compliance with a more severe duty, in which case he shall conduct a test for the most severe duty in accordance with Table 3. If a controller has already been tested and rated for a duty that is more severe than the standard duty, the manufacturer may assign the same rating for standard duty without further testing.

For utilization categories AC-52a, AC-53a, AC-58a, more severe test values for ON-time and OFF-time may be calculated by:

$$\text{ON-time (seconds)} = 36 F/S$$

$$\text{OFF-time (seconds)} = 36 (100-F)/S$$

For utilization categories AC-52b, AC-53b, AC-58b, the manufacturer may claim compliance with the capability to perform starting duty operations with OFF-times that are less than the 1 440 s that are allowed as standard. However, this shall be verified by testing with the OFF-time declared by the manufacturer.

For controllers or starters intended for intermittent, temporary, or periodic duty the manufacturer shall select from the arrays for F and S given in 5.3.4.6.

Table 9 – Minimum overload current withstand time (T_x) in relation to overload current ratio (X) and corresponding to overload relay trip class (see Table 19)

Designation (included as a guide only)	Minimum overload current withstand time s						
	$X = 8$	$X = 7$	$X = 6$	$X = 5$	$X = 4$	$X = 3$	$X = 2$
2	0,7	0,9	1,2	1,8	2,7	5	11
3	1	1,3	1,8	2,6	4	7	16
5	1,2	1,5	2	3	4,6	8,3	19
10A	1,6	2	3	4	6	12	26
10	3	4	6	8	13	23	52
20	5	6	9	12	19	35	78
30	7	9	13	19	29	52	112
40	11	15	20	29	45	80	180

Table 10 – Minimum requirements for thermal stability test conditions ^a

Utilization category	Form of controller ^e	Test current (I_T) Operating cycle ON-time s				Operating cycle OFF-time s
		Test level 1 ^a		Test level 2 ^a		
		I_T	ON-time ^b	I_T	ON-time ^b	
AC-52a	1, H1	$X I_e$	T_x	I_e	$2 \cdot 160 \cdot T_x$	$\leq 1 \ 440$
AC-53a	2, H2	$0,75 I_{LRP}$				
AC-58a	3, H3	I_{LRP}				
AC-52b	1, H1	$X I_e$	T_x	Zero ^c	Zero ^c	$\leq 1 \ 440$
AC-53b	2, H2	$0,75 I_{LRP}$				
AC-58b	3, H3	I_{LRP}				
Parameters of the test circuit:						
I_e = rated operational current						
I_T = test current						
U_T = test voltage (may be any value)						
Cos φ = test circuit power factor (may be any value)						
Number of operating cycles ^d						
^a Changeover time from level 1 to level 2 shall not be greater than three full periods of the power frequency.						
^b For a starter or a controller intended to be used only together with a specified overload relay, T_x is replaced by the maximum operating time allowed by the tolerances of its overload relay in the hot state.						
^c Level 2 is not applicable for AC-52b, AC-53b and AC-58b because this is an off-load period.						
^d The number of operating cycles will depend upon the length of time required for the controller to reach thermal equilibrium.						
^e For bypassed controllers refer to 8.2.2.4.3 and 8.2.2.4.4.						

Table 11 – Minimum requirements for overload capability test conditions

Utilization category	Parameters of the test circuit			Operating cycle ^d ON-time s	Operating cycle ^d off time s	Number of operating cycles
	I_{LRP} / I_e	U_r / U_e^a	$\text{Cos } \varphi^b$			
AC-52a AC-52b	4	1,05	0,65	T_x^c 9440		3
AC-53a AC-53b	8		e			
AC-58a AC-58b	6		e			
<p>I_{LRP} prospective locked rotor current I_e rated operational current U_e rated operational voltage U_r power frequency recovery voltage</p> <p><i>Temperature conditions:</i> Initial case temperature, C_i, for each test shall be not less than 40 °C plus the maximum case temperature rise during the temperature rise test (see 9.3.3.3). During the test, the ambient air temperature shall be between +10 °C and +40 °C.</p> <p>a $U_r / U_e = 1,05$ for the last three full periods of power frequency of the ON-time, plus the first second of the OFF-time (full voltage period). U_r / U_e may be any value during the time when the full voltage period is not in effect (reduced voltage period).</p> <p>b The characteristics of the circuit ($\text{cos } \varphi$ and maximum possible current) are mandatory during the full voltage period. During the reduced voltage period, the characteristics of the circuit are not mandatory provided the load circuit permits a current higher than $X \times I_e$.</p> <p>c For a starter or a controller intended to be used only together with a specified overload relay, T_x is replaced by the maximum operating time allowed by the tolerances of its overload relay in the hot state, which is the state of thermal equilibrium reached during the temperature rise test (see 9.3.3.3).</p> <p>d Changeover time shall not be greater than three full periods of the power frequency.</p> <p>e For $I_e \leq 100$ A: $\text{cos } \varphi = 0,45$, for $I_e > 100$ A: $\text{cos } \varphi = 0,35$.</p>						

Table 12 – Minimum requirements and conditions for performance testing with an induction motor load

Utilization category	Test motor parameters				External mechanical load parameters
	K	U / U_e	Power	$\text{Cos } \varphi$	
AC-52a AC-52b	≥ 4	a	a	a	a
AC-53a AC-53b					
AC-58a AC-58b					
<p>K ratio of locked rotor current to rated full load current of the test motor. During the test, the motor and the ambient air may be at any temperature between +10 °C and +40 °C.</p> <p>a The characteristics of the induction motor test load are specified in 8.2.4.3.</p>					

8.2.4.2 Making and breaking capacities for devices in the main circuit

8.2.4.2.1 General

The controller or starter, including the over-current releases and the mechanical switching devices associated with it, shall be capable of operating without failure in the presence of locked rotor motor current (starting current and overload current).

The capability of making and breaking currents without failure shall be verified under the conditions stated in both Table 13 and Table 14, for the required utilization categories, and the number of operations indicated.

8.2.4.2.2 Series mechanical switching devices of hybrid controllers

The series mechanical switching devices in the main circuit of controllers and starters shall meet the requirements of their own product standards, and the additional requirements of 8.2.4.2 when tested as a stand-alone device.

For bypassed hybrid controllers and starters (see Figure 1), the series mechanical switching device may be designated with a duty rating that is aligned with the intermittent duty rating (for example AC-53b) of the semiconductor controller.

The making and breaking capacity shall be verified by the procedures of 9.3.3.5.1 and 9.3.3.5.2.

8.2.4.2.3 Type tested, parallel mechanical switching devices of bypassed controllers

The making and breaking capacity shall be verified when tested as a stand-alone device in accordance with the procedures of 9.3.3.5.1 and 9.3.3.5.3.

8.2.4.2.4 Dependent, parallel mechanical switching devices of bypassed controllers

The making and breaking capacity shall be verified when tested as a combined unit in accordance with the procedures of 9.3.3.5.1 and 9.3.3.5.4.

8.2.4.2.5 Semiconductor switching devices

The capability to control overload currents shall be verified by the procedures of 9.3.3.6.2 and 9.3.3.6.3.

8.2.4.3 Requirements for an induction motor test load

The induction motor test load shall feature a four-pole squirrel cage motor with the following characteristics:

- a) the rated voltage of the motor shall be equal to or greater than U_e for the device to be tested;
- b) when the motor is running, the test current through the motor and the controller may be any value greater than 1 A;
- c) the power factor of the motor may be of any value;
- d) the inner connections of the motor windings may be of any configuration (for example star, delta);
- e) the parameters of the mechanical load connected to the motor shaft shall be adjusted to produce a decelerating time from base speed to zero speed within the range of 2 s to 4 s.

Table 13 – Making and breaking capacity test; making and breaking conditions according to utilization categories for the mechanical switching device of hybrid motor controllers H1, H2, H3 and for certain forms of bypassed controllers

Utilization category	Make and break conditions					
	I_c/I_e	U_r/U_e	$\text{Cos } \varphi$	ON-time s	OFF-time s	Number of operating cycles
AC-52a, b	4,0	1,05	0,65	0,05	b	50
AC-53a, b	8,0		a			
AC-58a, b	6,0		a			
I_c = current made and broken, expressed in a.c. r.m.s. symmetrical values I_e = rated operational current U_e = rated operational voltage U_r = power frequency recovery voltage				Current I_c A	OFF-time s	
a For $I_e \leq 100$ A: $\text{Cos } \varphi = 0,45$ For $I_e > 100$ A: $\text{Cos } \varphi = 0,35$ b OFF-time shall not be greater than the values given in the chart.				$I_c \leq 100$	10	
				$100 < I_c \leq 200$	20	
				$200 < I_c \leq 300$	30	
				$300 < I_c \leq 400$	40	
				$400 < I_c \leq 600$	60	
				$600 < I_c \leq 800$	80	
				$800 < I_c \leq 1\ 000$	100	
				$1\ 000 < I_c \leq 1\ 300$	140	
				$1\ 300 < I_c \leq 1\ 600$	180	
				$1\ 600 < I_c$	240	

Table 14 – Conventional operational performance making and breaking conditions according to utilization categories for the mechanical switching device of hybrid motor controllers H1B, H2B, H3B and for certain forms of bypassed controllers

Utilization category	Make and break conditions					
	I_c/I_e	U_r/U_e	$\text{Cos } \varphi$	ON-time s	OFF-time s	Number of operating cycles
AC-52a, b	2,0	1,05	0,65	0,05	b	6 000
AC-53a, b	2,0	1,05	a			
AC-58a, b	6,0	1,05	0,35	1 10	9 90	5 900 100
I_c = current made and broken, expressed in a.c. r.m.s. symmetrical values I_e = rated operational current U_e = rated operational voltage U_r = power frequency recovery voltage						
a For $I_e \leq 100$ A: $\text{Cos } \varphi = 0,45$ For $I_e > 100$ A: $\text{Cos } \varphi = 0,35$						
b OFF-times shall not be greater than the values given in Table 13.						

8.2.5 Co-ordination with short-circuit protective devices

8.2.5.1 Performance under short-circuit conditions

The rated conditional short-circuit current of controllers and starters backed up by short-circuit device(s) (SCPDs) shall be verified by short-circuit tests as specified in 9.3.4. These tests are mandatory.

The rating of the SCPD shall be adequate for any given rated operational current, rated operational voltage and the corresponding utilization category.

Two types of co-ordination are permissible, type 1 or type 2. Test conditions for both are given in 9.3.4.3.

Type 1 co-ordination requires that, under short-circuit conditions, the device shall cause no danger to persons or installation and may not be suitable for further service without repair and replacement of parts.

Type 2 co-ordination requires that, under short-circuit conditions, the device shall cause no danger to persons or installation and shall be suitable for further use. For hybrid controllers and starters, the risk of contact welding is recognized, in which case the manufacturer shall indicate the measures to be taken as regards the maintenance of the equipment.

NOTE Use of a SCPD not in compliance with the manufacturer's recommendations may invalidate the co-ordination.

8.2.5.2 Co-ordination at the crossover current between the starter and the SCPD

This may be verified by a special test (see 9.1.5).

8.3 EMC requirements

8.3.1 General

It is widely accepted that the achievement of electromagnetic compatibility between different items of electrical and electronic apparatus is a desirable objective. Indeed, in many countries, mandatory requirements for EMC exist.

The requirements specified in the following subclauses are included to permit the achievement of electromagnetic compatibility for controllers and starters. All relevant immunity and emission requirements are covered, and additional tests are not required or necessary. EMC performance is not guaranteed in the event that the controller or starter is subject to electronic component failure. These conditions are not considered, and do not form part of the test requirements.

All phenomena, whether emission or immunity, are considered individually: the limits given are for conditions which are not considered to have cumulative effects.

For EMC test, the minimum system to be considered is the controller or starter interconnected with a motor and cables. The tests are to be conducted as follows:

For immunity tests, the complete duty cycle of the Soft starter is to be considered, including the starting time and the stopping time.

For emission limit tests, only the steady state condition is to be considered.

NOTE 1 Under consideration, no suitable measurement technique and equipment are currently available for non-steady states conditions.

NOTE 2 It is the responsibility of the installer (who may also be the manufacturer of controllers and starters) to ensure that systems containing controllers or starters comply with any requirements applicable at the systems level.

These clauses do not describe or affect the safety requirements for a controller or starter such as protection against electric shocks, insulation co-ordination, and related dielectric tests, unsafe operation, or unsafe consequence of a failure.

8.3.2 Emission

Subclause 7.3.3.2 of IEC 60947-1:2007 applies according to the relevant set of environmental conditions defined in 7.3.1 of IEC 60947-1:2007. The relevant set of environmental condition must be stated in the information to be given with the equipment.

8.3.2.1 Low-frequency emission with reference to main power frequency

8.3.2.1.1 Harmonics

Subclause 7.3.3.2.2 of IEC 60947-1:2007 applies with the following addition:

Because no significant harmonic emissions are produced in the FULL-ON state, tests are not required on those controllers or starters which run only in the FULL-ON state or which are by-passed by a mechanical switching device after completing a start, for example, Forms 2 and 3 and certain Form 1 controllers or starters.

8.3.2.1.2 Voltage fluctuation

This phenomenon does not arise from the action of a controller or starter, therefore no tests are required.

8.3.2.2 High-frequency emission

8.3.2.2.1 Conducted radio-frequency (RF) emission

The limits given in Table 19 shall be verified in accordance with the procedures of 9.3.5.1.1.

8.3.2.2.2 Radiated emission

The limits given in Table 20 shall be verified in accordance with the procedures of 9.3.5.1.2.

8.3.3 Immunity

8.3.3.1 General

Electrical system influences may be destructive or non-destructive, depending on the intensity of the influence. Destructive influences (voltage or current) cause irreversible damage to a controller or starter. Non-destructive influences may cause temporary malfunction or abnormal operation, but the controller or starter returns to normal operation after the influence is minimized or removed; in some cases, this may require manual intervention.

The manufacturer should be consulted in those instances where severe external influences may occur, which are greater than the levels for which the controller or starter has been tested, for example installations in remote locations with long power transmission lines; close proximity to ISM equipment as defined in CISPR 11.

NOTE The careful application of decoupling practices during installation helps to minimize the external transient influences. For example, control circuit wiring should be separated from power circuit wiring. Where closely coupled wiring cannot be avoided, twisted pairs or shielded wiring should be used for control circuit connections.

A number of requirements are listed. The test results are specified using the performance criteria of the IEC 61000-4 series. For convenience, the performance criteria are quoted here, and described in more specific detail in Table 15.

These are

- 1) normal performance within the specification limits;
- 2) temporary degradation, or loss of function or performance, which is self-recoverable;
- 3) temporary degradation, or loss of function or performance, which requires operator intervention or system reset. Normal functions must be restorable by simple intervention, such as by manual reset or restart. There must not be any damaged components.

In Table 15, the acceptance criteria are described for overall performance (A), which are used when a complete controller or starter is tested. When it is not possible to test the complete controller or starter, the functional element performances (B,C,D) are to be used.

Table 15 – Specific acceptance or performance criteria when EM disturbances are present

Item	Acceptance criteria (performance during test)		
	1	2	3
A Overall performance	No noticeable changes of the operating characteristic. Operating as intended.	Noticeable changes (visual or audible) of the operating characteristic. Self-recoverable.	Changes in operating characteristic. Triggering of protective devices. Not self-recoverable.
B Operation of power and driving circuits	No maloperation.	Temporary maloperation which cannot cause tripping, or erratic and audible changes in motor torque.	Shut down. Triggering of protective devices. Not self-recoverable.
C Operation of displays and control panels	No changes to visible display information. Only slight light intensity fluctuation of LEDs, or slight movement of characters.	Temporary visible changes or loss of information. Undesired LED illumination	Shut down. Permanent loss or display of wrong information. Unpermitted operating mode. Not self-recoverable.
D Information processing and sensing functions	Undisturbed communication and data interchange to external devices.	Temporarily disturbed communication, with possible error reports of the internal and external devices.	Erroneous processing of information. Loss of data and/or information. Errors in communication. Not self-recoverable.

8.3.3.2 Electrostatic discharge

The test values and procedures are given in 9.3.5.2.1.

8.3.3.3 Radio-frequency electromagnetic field

The test values and procedures are given in 9.3.5.2.2.

8.3.3.4 Fast transients (common mode) (5/50 ns)

The test values and procedures are given in 9.3.5.2.3.

8.3.3.5 Surges (1,2/50/μs-8/20/μs)

The test values and procedures are given in 9.3.5.2.4.

8.3.3.6 Harmonics and commutation notches

The test values and procedures are given in 9.3.5.2.5.

8.3.3.7 Voltage dips and short time interruptions

The test values and procedures are given in 9.3.5.2.6.

8.3.3.8 Power frequency magnetic field

Tests are not required. Immunity is demonstrated by the successful completion of the operating capability test (see 9.3.3.6).

9 Tests

9.1 Kinds of tests

9.1.1 General

Subclause 8.1.1 of IEC 60947-1:2007 applies.

9.1.2 Type tests

Type tests are intended to verify compliance of the design of controllers and starters of all forms with this standard. They comprise the verification of

- a) temperature-rise limits (9.3.3.3);
- b) dielectric properties (9.3.3.4);
- c) operating capability (9.3.3.6);
- d) operation and operating limits (9.3.3.6.3);
- e) rated making and breaking capacity and conventional operational performance of series mechanical switching devices of hybrid equipment (9.3.3.5);
- f) performance under short-circuit conditions (9.3.4);
- g) mechanical properties of terminals (8.2.4 of IEC 60947-1:2007 applies);
- h) degrees of protection of enclosed controllers and starters (Annex C of IEC 60947-1:2007 applies);
- i) EMC tests (9.3.5).

9.1.3 Routine tests

Subclause 8.1.3 of IEC 60947-1:2007 applies where sampling tests (9.1.4) are not made instead.

Routine tests for controllers and starters comprise

- operation and operating limits (9.3.6.2);
- dielectric tests (9.3.6.3).

9.1.4 Sampling tests

Sampling tests for controllers and starters comprise

- operation and operating limits (9.3.6.2);
- dielectric tests (9.3.6.3).

Subclause 8.1.4 of IEC 60947-1:2007 applies, with the following amplification:

A manufacturer may use sampling tests instead of routine tests at his own discretion. Sampling shall meet or exceed the following requirements, as specified in IEC 60410 (see Table II-A of IEC 60410:1973).

Sampling is based on AQL ≤ 1 :

- acceptance number $A_c = 0$ (no defect accepted);
- rejection number $R_e = 1$ (if 1 defect, the entire lot shall be tested).

Sampling shall be made at regular intervals for each specific lot.

Alternative statistical methods that ensure compliance with the above IEC 60410 requirements can be used, for example statistical methods controlling continuous manufacturing or process control with capability index.

Sampling tests for clearance verification according to 8.3.3.4.3 of IEC 60947-1:2007 are under consideration.

9.1.5 Special tests

9.1.5.1 General

Special tests comprise verification of co-ordination at the crossover current between the starter and the SCPD (see Annex C) and those tests covered under 9.1.5.2.

9.1.5.2 Special tests – damp heat, salt mist, vibration and shock

For these special tests, Annex Q of IEC 60947-1:2007 applies. The conditions of application are under consideration.

9.2 Compliance with constructional requirements

Subclause 8.2 of IEC 60947-1:2007 applies.

9.3 Compliance with performance requirements

9.3.1 Test sequences

Each test sequence is made on a new sample.

NOTE 1 With the agreement of the manufacturer, more than one test sequence, or all sequences, may be conducted on one sample. However, the tests are to be conducted in the sequence given for each sample.

NOTE 2 Some tests are included in the sequences solely to reduce the number of samples required; the results have no significance for the preceding or following tests in the sequence. Therefore, for convenience of testing and by agreement with the manufacturer, these tests may be conducted on separate new samples and omitted from the relevant sequence. This only applies to the following tests when called for:

8.3.3.4.1 item 7) of IEC 60947-1:2007: *Verification of creepage distance;*

8.2.4 of IEC 60947-1:2007: *Mechanical properties of terminals;*

Annex C of IEC 60947-1:2007: *Degrees of protection of enclosed equipment.*

The test sequence shall be as follows:

a) Test sequence I

- 1) Verification of temperature rise (9.3.3.3)
- 2) Verification of dielectric properties (9.3.3.4)
- b) *Test sequence II: Operating capability verification (9.3.3.6)*
 - 1) Thermal stability test (9.3.3.6.1)
 - 2) Overload capability test (9.3.3.6.2)
 - 3) Blocking and commutating capability test (9.3.3.6.3), including verification of operation and operating limits
- c) *Test sequence III*
Performance under short-circuit conditions (9.3.4)
- d) *Test sequence IV*
 - 1) Verification of mechanical properties of terminals (8.2.4 of IEC 60947-1:2007)
 - 2) Verification of degrees of protection of enclosed equipment (Annex C of IEC 60947-1:2007)
- e) *Test sequence V*
EMC tests (9.3.5)
- f) *Test sequence VI*
Tripping test (9.3.3.6.5)

9.3.2 General test conditions

Subclause 8.3.2 of IEC 60947-1:2007 applies with the following addition.

Except for devices specifically rated for only one frequency, tests performed at 50 Hz cover 60 Hz applications and vice-versa.

The selection of samples to be tested for a series of devices with the same fundamental design and without a significant difference in construction shall be based on engineering judgement.

Unless otherwise specified in the relevant test clause, the clamping torque for connections shall be that specified by the manufacturer or, if not specified, the torque given in Table 4 of IEC 60947-1:2007.

In the case where several heat sinks are specified, the one which has the higher thermal resistance shall be used.

True r.m.s. voltage and current measuring means shall be used.

9.3.3 Performance under no load, normal load, and overload conditions

9.3.3.1 Vacant

9.3.3.2 Vacant

9.3.3.3 Temperature rise

9.3.3.3.1 Ambient air temperature

Subclause 8.3.3.3.1 of IEC 60947-1:2007 applies.

9.3.3.3.2 Measurement of the temperature of parts

Subclause 8.3.3.3.2 of IEC 60947-1:2007 applies.

9.3.3.3.3 Temperature rise of a part

Subclause 8.3.3.3.3 of IEC 60947-1:2007 applies.

9.3.3.3.4 Temperature rise of the main circuit

Subclause 8.3.3.3.4 of IEC 60947-1:2007 applies with the exception that a single phase test shall be conducted with all poles in the main circuit loaded at their individual maximum rated currents and as stated in 8.2.2.4, and with the following additions:

For semiconductor switching devices connected in the main circuit (see 8.2.2.4), temperature sensing means shall be attached to the outer surface of the case of the semiconductor switching device that is most likely to produce the highest temperature rise during this test. The final case temperature, C_f , and the final ambient temperature, A_f , shall be recorded for use in the test of 9.3.3.6.2.

For mechanical switching devices (see 8.2.2.4.2 and 8.2.2.4.4), temperature sensing means shall be attached in accordance with the requirements of 8.3.3.3 of IEC 60947-1:2007.

All auxiliary circuits which normally carry current shall be loaded at their maximum rated operational current (see 5.6), and the control circuits shall be energized at their rated voltages.

Starters shall be fitted with an overload relay, complying with 5.7, and selected as follows:

- non-adjustable relay:
the current setting shall be equal to the maximum operational current of the starter, and the test shall be at this current;
- adjustable relay:
the maximum current setting shall be that which is nearest to, but not greater than, the maximum operational current of the starter.

For starters, the test shall be made with that overload relay for which the current setting is nearest to the maximum of its scale.

NOTE The selection method described above is designed to ensure that the temperature rise of these field wiring terminals of the overload relay, and the power dissipated by the starter, are not less than those that will occur under any combination of relay and controller. In cases where the effect of the overload relay on these values is insignificant (as in solid-state overload relays), the test current should always be the maximum operational current of the starter.

9.3.3.3.5 Temperature rise of control circuits

Subclause 8.3.3.3.5 of IEC 60947-1:2007 applies, with the following addition:

The temperature rise shall be measured during the test of 9.3.3.3.4.

9.3.3.3.6 Temperature rise of coils and electromagnets

Subclause 8.3.3.3.6 of IEC 60947-1:2007 applies with the following addition:

Electromagnets of contactors or starters intended for duty within semiconductor controllers or for mechanical bypass switching means shall comply with 8.2.2.6 with rated current flowing through the main circuit for the duration of the test. The temperature rise shall be measured during the test of 9.3.3.3.4.

9.3.3.3.7 Temperature rise of auxiliary circuits

Subclause 8.3.3.3.7 of IEC 60947-1:2007 applies, with the following addition:

The temperature rise shall be measured during the test of 9.3.3.3.4.

9.3.3.4 Dielectric properties

9.3.3.4.1 Type tests

(1) General conditions for withstand voltage tests

Subclause 8.3.3.4.1 1) of IEC 60947-1:2007 applies except the last note. See also 8.2.3.

(2) Verification of impulse withstand voltage

a) General

Subclause 8.3.3.4.1 2) a) of IEC 60947-1:2007 applies.

b) Test voltage

Subclause 8.3.3.4.1 2) b) of IEC 60947-1:2007 applies with the following sentence added.

For any part for which the dielectric properties are not sensitive to altitude (for example opto-coupler, potted parts, etc.) the correction factor for altitude is not applicable.

c) Application of test voltage

With the equipment mounted and prepared as specified in item 1) above, the test voltage is applied as follows:

i) between all the terminals of the main circuit connected together (including the control and auxiliary circuits connected to the main circuit) and the enclosure or mounting plate, with the contacts, if any, in all normal positions of operation;

ii) for poles of the main circuit declared galvanically separated from the other poles: between each pole and the other poles connected together and to the enclosure or mounting plate, with the contacts, if any, in all normal positions of operation;

iii) between each control and auxiliary circuit not normally connected to the main circuit and

- the main circuit;
- the other circuits;
- the exposed conductive parts;
- the enclosure or mounting plate, which, wherever appropriate, may be connected together;

iv) for equipment suitable for isolation, across the poles of the main circuit, the line terminals being connected together and the load terminals connected together. The test voltage shall be applied between the line and load terminals of the equipment with the contacts in the isolated open position and its value shall be as specified in item 1) b) of 7.2.3.1 of IEC 60947-1:2007.

d) Acceptance criteria

Subclause 8.3.3.4.1 2) d) of IEC 60947-1:2007 applies.

(3) Power-frequency withstand verification of solid insulation

a) General

Subclause 8.3.3.4.1 3) a) of IEC 60947-1:2007 applies.

b) Test voltage

Subclause 8.3.3.4.1 3) b) of IEC 60947-1:2007 applies with the following sentence added at the end of the first paragraph.

If an alternating test voltage cannot be applied due to the EMC filter components, which cannot easily be disconnected, a direct test voltage may be used having the same value as the crest value of the projected alternating test voltage.

c) Application of test voltage

Subclause 8.3.3.4.1 3) c) of IEC 60947-1:2007 applies with the two last sentences modified as follows:

The test voltage shall be applied for 5 s, with the following conditions:

- in accordance with items i), ii) and iii) of 2) c) above;
- for hybrid semiconductor controller or starters, across the poles of the main circuit, the line terminals being connected together and the load terminals connected together.

d) Acceptance criteria

Subclause 8.3.3.4.1 3) d) of IEC 60947-1:2007 applies.

(4) Power-frequency withstand verification after switching and short-circuit tests

a) General

Subclause 8.3.3.4.1 4) a) of IEC 60947-1:2007 applies.

b) Test voltage

Subclause 8.3.3.4.1 4) b) of IEC 60947-1:2007 applies.

c) Application of test voltage

Subclause 8.3.3.4.1 4) c) of IEC 60947-1:2007 applies with the following sentence added at the end of the paragraph.

The use of a metal foil, as mentioned in 8.3.3.4.1 1) of IEC 60947-1:2007, is not required.

d) Acceptance criteria

Subclause 8.3.3.4.1 4) d) of IEC 60947-1:2007 applies.

(5) Vacant

(6) Verification of d.c. withstand voltage

Subclause 8.3.3.4.1 6) of IEC 60947-1:2007 applies.

(7) Verification of creepage distances

Subclause 8.3.3.4.1 7) of IEC 60947-1:2007 applies.

(8) Verification of leakage current of equipment suitable for isolation

The maximum leakage current shall not exceed the values of 7.2.7 of IEC 60947-1:2007.

9.3.3.4.2 Vacant

9.3.3.4.3 Sampling tests for verification of clearances

(1) General

Subclause 8.3.3.4.3 1) of IEC 60947-1:2007 applies.

(2) Test voltage

The test voltage shall be that corresponding to the rated impulse withstand voltage.

Sampling plans and procedure are under consideration.

(3) Application of test voltage

Subclause 8.3.3.4.3 3) of IEC 60947-1:2007 applies.

(4) Acceptance criteria

Subclause 8.3.3.4.3 4) of IEC 60947-1:2007 applies.

9.3.3.5 Making and breaking capacity of mechanical switching devices

9.3.3.5.1 General

It shall be verified that mechanical switching devices meet the requirements of 8.2.4.2.

If the mechanical switching device has not passed previous tests, compliance with the following subclauses of 8.2.4.2 is required. The making and breaking capacity shall be verified in accordance with 8.3.3.5 of IEC 60947-1:2007.

9.3.3.5.2 Series mechanical switching devices of hybrid controllers

- a) The subject device may be tested as a separate component, or
- b) the complete hybrid controller may be tested with the subject devices installed as in normal service and with the semiconductor components of each pole shorted out.

9.3.3.5.3 Type tested parallel mechanical switching devices of bypassed controllers

The subject device shall be tested as a separate device.

9.3.3.5.4 Dependent, parallel mechanical switching devices of bypassed controllers

The complete unit with bypass installed shall be tested as in normal service. The operational sequence, to simulate starting and stopping, shall be the same as in normal service.

9.3.3.6 Operating capability

Compliance with the operating capability requirements of 8.2.4.1 shall be verified by the following three tests:

- thermal stability test;
- overload capability test;
- blocking and commutation capability test.

The tests simulate 8 h duty.

Connections to the main circuit shall be similar to those intended to be used when the equipment is in service. The control voltage shall be fixed at 110 % of the rated control supply voltage, U_s .

If the controller within a starter has satisfied the requirements of a previous operating capability test, and meets the requirements for assigning ratings based on the results of test as given in 5.4.2, the starter need not be tested.

Table 16 – Thermal stability test specifications

Item	Level	Instructions
Test objective		To verify that the temperature variation between successive identical operating cycles in a sequence reduces to less than 5 % within an 8 h period. To verify that the temperature rise of the accessible terminals of the mechanical switching device in the main circuit does not exceed the limit prescribed by Table 2 of IEC 60947-1:2007.
Test duration		Run test until $\Delta_n \leq 0,05$ or 8 h have elapsed $\Delta_n = (C_n - C_{n-1} - A_0) / (C_{n-1})$
Test conditions	Table 10	
EUT temperature	C_n , case temperature	Temperature sensing means attached to the outer surface of one semiconductor switching device (9.3.3.3.4). Monitor the semiconductor switching device that is likely to be the hottest.
Ambient temperature	A_n , any level convenient	Temperature sensing means to monitor changes in ambient temperature (8.3.3.3.1 of IEC 60947-1:2007 applies).
Results to be obtained		a) $\Delta_n \leq 0,05$ within 8 h b) No visual evidence of damage (such as smoke, discoloration) c) The temperature rise of the accessible terminals of the mechanical switching device in the main circuit shall not exceed the limit prescribed by Table 2 of IEC 60947-1:2007. d) When the terminals are not accessible, the values of Table 2 of IEC 60947-1:2007 may be exceeded provided that adjacent parts are not impaired.

Table 17 – Initial case temperature requirements

Operating cycle number	Initial case temperature, C_i °C
1	Not less than 40 °C
2	Highest temperature enabling resetting after the first operating cycle of the overload relay of the starter, or the overload relay recommended by the manufacturer to be used together with the controller.
3 and 4	≥ 40 °C plus the maximum case temperature rise during the temperature rise test (9.3.3.3)

9.3.3.6.1 Thermal stability test procedure

Test specifications and acceptance criteria are given in Table 16. The test profiles are illustrated in Figure F.1.

- (1) Assign a sequence number, n , to each on-load period in the test series (as $n = 0, 1, 2, \dots, n-1, N$).
- (2) Record initial case temperature C_0 . Record initial ambient temperature A_0 .
- (3) Set test current, I_T , level 1 (see Table 10). Change n to a new value where $n = n+1$.
- (4) Apply test voltage, U_T , to the input main circuit terminals of the EUT (equipment under test). U_T may remain applied for the duration of the test, or may be switched ON-OFF in synchronism with the operation of control voltage, U_C .

Switch EUT to ON-state (EUT control voltage, U_C , is ON).

NOTE The time span of T_x commences at the instant when the test current reaches the value $X \times I_e$. Therefore, the time for the test current ramp to reach $X \times I_e$ increases the total test time.

- (5) This step needs to be performed with respect to the utilization category.
 - a) For AC-52a, AC-53a, AC-58a only.

After time interval T_x (Table 10), change test current, I_t , to level 2.
After time interval for level 2, switch EUT to OFF-state.

- b) For AC-52b, AC-53b, AC-58b only.
After time interval T_x (Table 10), switch EUT to OFF-state.
- (6) Record case temperature C_n . Record ambient temperature A_n .
- (7) Decision to terminate (or continue) test:

- a) Calculate case temperature rise change factor:

$$\Delta_n = (C_n - C_{n-1} - A_n + A_{n-1}) / (C_{n-1} - A_{n-1})$$

- b) Check compliance with results to be obtained (Table 16)

If $\Delta_n > 0,05$, total test time is less than 8 h, and results to be obtained (a) and b) of Table 16) are not violated, repeat steps 3 to 7.

If $\Delta_n > 0,05$, and total test time is greater than 8 h, or results to be obtained are violated, end test. This is a failure.

If $\Delta_n \leq 0,05$, and total test time is less than 8 h, and results a), b), c) and d) of Table 16 are not violated, end test. This is successful compliance.

9.3.3.6.2 Overload capability test procedure

(1) Test conditions

- a) Refer to Table 11. The test profile is represented in Figure F.2.
- b) Controllers and starters, utilizing a current controlled cut-out device in addition to an overload relay to provide protection against overload conditions during running in the FULL-ON state, shall be tested with the cut-out device in place. In this test, it is acceptable for the cut-out device to switch the EUT to the OFF-state in a time shorter than the specified ON-time.

(2) EUT adjustments

- a) EUT shall be adjusted to minimize the time to establish the test current level, I_{LRP} .
- b) EUT fitted with a current-limit function shall be set to the highest value of X specified for I_e .
- c) Where the EUT is a starter, its overload relay shall be disabled, and T_x shall be set in accordance with c) of Table 11.

(3) Test

- a) Establish initial conditions.
- b) Apply test voltage to the input main circuit terminals of the EUT.
(With form HxA, the series mechanical switching device contact is closed. With form HxB, the series mechanical switching device is open.)
The test voltage shall be applied for the duration of the test.
- c) Switch the EUT to ON-state.
- d) After the ON-time (Table 11), switch the EUT to the OFF-state.

NOTE In the case of form HxB, the OFF-state will be replaced by the OPEN-state.

- e) Repeat steps c) and d) twice. End test.

In the case of the EUT having a current limit function during motor starting (and possibly stopping), but not in the FULL-ON state, the overload capability test procedure for verification of compliance of the EUT with the requirements of 8.2.4.1 is the following.

- i) After two operating cycles as described above, the EUT is switched to the ON-state, and loaded with an initial test current I_{init} , not higher than I_e .
- ii) With the EUT in the FULL-ON state, the test circuit specified in Table 11 is connected to the load by means of an external switch. There shall be no current interruption during transition from current I_{init} to I_{LRP} .

iii) In accordance with Table 9, the test current I_{LRP} is maintained for T_x seconds before an OFF-state is established by the EUT. The EUT is, however, permitted to establish an OFF-state condition at shorter times than T_x , provided it is equipped with a suitable overload protection.

iii) This operating cycle is performed twice.

The initial case temperature conditions for the required four operating cycles shall be as stated in Table 17.

(4) *Verify the criteria (see 9.3.3.6.4)*

- a) No loss of commutating capability.
- b) No loss of blocking capability.
- c) No loss of functionality.
- d) No visual evidence of damage.

Table 18 – Blocking and commutating capability test specifications

Item	Level	Instruction
Number of operating cycles	Test 1: 100 operating cycles with 85 % U_e and 85 % U_s . Test 2: 1 000 operating cycles with 110 % U_e and 110 % U_s .	
Test load	The parameters of the induction motor and the mechanical load are given in Table 12.	
Test instrument	True r.m.s. current measuring means shall be connected between the motor terminals and the load side terminals on each pole of the EUT. The means shall be capable of measuring currents in the range of milliamperes.	
EUT temperature	Room temperature (10 °C to 40 °C)	
EUT settings	<p>EUT settings are limited to only those external adjusting means provided by the manufacturer in the normal product offerings.</p> <p>a) Controllers fitted with a current-limit function will be set at the lowest value of X that will allow the motor (as defined in Table 12) to start.</p> <p>b) Controllers fitted with ramp-start functions will be set at the maximum ramping time or 10 s, whichever is less.</p> <p>Initial values of starting current and/or starting voltage will be set at the minimum value that will allow the motor to start immediately.</p>	
Test cycle	<p>ON-time >time to achieve full voltage and full speed + 1 s</p> <p>OFF-time = 1/3 of the time for coasting to rest.</p>	
Results to be obtained	<p>a) a1) or a2) shall be fulfilled</p> <p>a1) $I_O < 1$ mA and $I_F < 1$ mA</p> <p>a2) if $I_O > 1$ mA or $I_F > 1$ mA, then</p> <ul style="list-style-type: none"> – $\Delta I < 1$ for each pole where $\Delta I = (I_F - I_O) / I_O$ <p>and</p> <ul style="list-style-type: none"> – I_O and I_F shall be within the limits given in the datasheet for the semiconductor. <p>b) No visual evidence of damage (such as smoke, discoloration).</p> <p>c) No loss of functionality as specified by the manufacturer.</p>	

9.3.3.6.3 Blocking and commutating capability test

Test specifications are given in Table 12 and Table 18. The test profiles are shown in Figure F.3.

For form HxA, the contacts of the series mechanical switching device shall be maintained in the closed position for the duration of the test.

For form HxB, the contacts of the series mechanical switching device may be operated to perform the testing cycles. However, the measurements of voltage across the poles shall be performed with the series contacts closed, and with the semiconductor switching devices in the OFF-state. The manufacturer shall provide instructions for fitting the EUT with special features that will permit compliance with the voltage measurement requirements.

- 1) The EUT shall be mounted and connected as in normal use with cable lengths between the EUT and test load not greater than 10 m.
- 2) The current measuring means shall be installed in a manner that is appropriate for recording the values of the leakage current through the controller (in steps 3) and 7).

If other auxiliary circuits or devices are connected in parallel with the semiconductor elements, care shall be taken in order to avoid measuring the parallel currents; only the leakage current of the semiconductor elements shall be measured and the means for obtaining those measures shall be installed accordingly.

- 3) With the voltages U_e and U_s applied to the EUT, and with the control voltage U_c OFF, measure the current through each pole of the EUT and record these measurements as a set of initial data points, I_0 .

The test circuit shall remain closed from the start of step 4) through the completion of step 7). The current measuring means may be shorted by remote control means during steps 5) and 6), but it may not be removed by opening the circuit.

- 4) To start the test, the voltages U_e and U_s (as specified in Table 18) are applied to the EUT and maintained for the duration of the test through the completion of step 7).
- 5) By means of the control voltage, U_c , cycle the EUT between the ON-state and OFF-state as specified in Table 18. If the controller does not perform as intended, or if evidence of damage develops, the test is discontinued, and considered a failure.
- 6) After the required number of operating cycles, turn U_c to OFF with U_e and U_s remaining ON. Allow the EUT to return to the initial ambient temperature.
- 7) Repeat the current measurement procedure of step 3) and record as a set of final data points, I_F , corresponding to the set of initial data points, I_0 .
- 8) Determine the values regarding the leakage currents through each pole as specified under item a) of Table 18.

To obtain successful compliance, the criteria given under item a), b) and c) of Table 18 shall be fulfilled.

9.3.3.6.4 Behaviour of the controller or starter during, and condition after, the operating capability tests

a) *Commutating capability*

If semiconductor devices do not commute properly, the early stage of the failure mode is evidenced by degraded performance. Continued operation in this mode will cause thermal runaway. The ultimate result will be excessive heating and loss of blocking capability.

b) *Thermal stability*

Semiconductor devices subject to rapid operating cycles may not cool properly. The early effects may initiate a thermal runaway condition leading to loss of blocking capability.

c) *Blocking capability*

Blocking capability is the ability to turn OFF and remain OFF whenever required. Excessive thermal stress will degrade blocking capability. The failure mode is evidenced by a partial or total loss of control.

d) *Functionality*

Some failure modes may not be catastrophic in the early stages. These failures are evident from gradual loss of function. Early detection and correction may prevent permanent damage.

e) *Visual inspection*

In the end, excessive thermal stresses due to elevated temperatures may cause permanent damage. Visual evidence (smoke or discoloration) provides early warning of ultimate failure.

9.3.3.6.5 Relays and releases

a) Operation of under-voltage relays and releases

Vacant.

b) Shunt-coil operated releases

Vacant.

c) Thermal and electronic overload relays

Overload relays and starters shall be connected using conductors in accordance with Tables 9, 10 and 11 of IEC 60947-1:2007 for test currents corresponding to

- 100 % of the current setting of the overload relay for overload relays of trip classes 2, 3, 5 and 10 A for all overload relay types (see Table 4) and 10, 20, 30 and 40 for electronic overload relay types;
- 125 % of the current setting of the overload relay for thermal overload relays of trip classes 10, 20, 30 and 40 (see Table 4) and for overload relays for which a maximum tripping time greater than 40 s is specified (see 5.7.3).

It shall be verified that relays and releases operate according to the requirements of 8.2.1.5.1.1 with all poles energized.

Moreover, the characteristics defined in 8.2.1.5.1 shall be verified by tests at 0 °C, +20 °C, +40 °C and may be verified at minimum and maximum temperatures given by the manufacturer if larger. However, for relays or releases declared compensated for ambient temperature, in case of temperature range declared by the manufacturer larger than those given in Table 5, the characteristics at 0°C and/or +40°C need not be verified if, when tested at the declared minimum and maximum temperatures, the corresponding tripping current values are in compliance with the limits specified for 0°C and/or +40°C in that Table 5.

For electronic overload relays, the thermal memory test verification of 8.2.1.5.1.1.2 shall be carried out at +20 °C.

Three-pole thermal or electronic overload relays energized on two poles only shall be tested as stated in 8.2.1.5.1.2 on all combinations of poles and at the maximum and minimum current settings for relays with adjustable settings.

d) Under-current relays

The limits of operation shall be verified in accordance with 8.2.1.5.3.

e) Stall relays

The limits of operation shall be verified in accordance with 8.2.1.5.4.

For current sensing stall relays, the verification shall be made for the minimum and for the maximum set current values and for the minimum and maximum stall inhibit time (four settings).

For stall relays operating in conjunction with a rotation sensing means, the verification shall be made for the minimum and maximum stall inhibit time. The sensor can be simulated by an appropriate signal on the sensor input of the stall relay.

f) Jam relays

The limits of operation shall be verified in accordance with 8.2.1.5.5.

The verification shall be made for the minimum and for the maximum set current values and for the minimum and maximum jam inhibit time (four settings).

For each of the four settings, the test shall be made under the following conditions:

- apply a test current of 95 % of the set current value. The jam relay shall not trip;

- increase the test current to 120 % of the set current value. The jam relay shall trip according to the requirements given in 8.2.1.5.5.

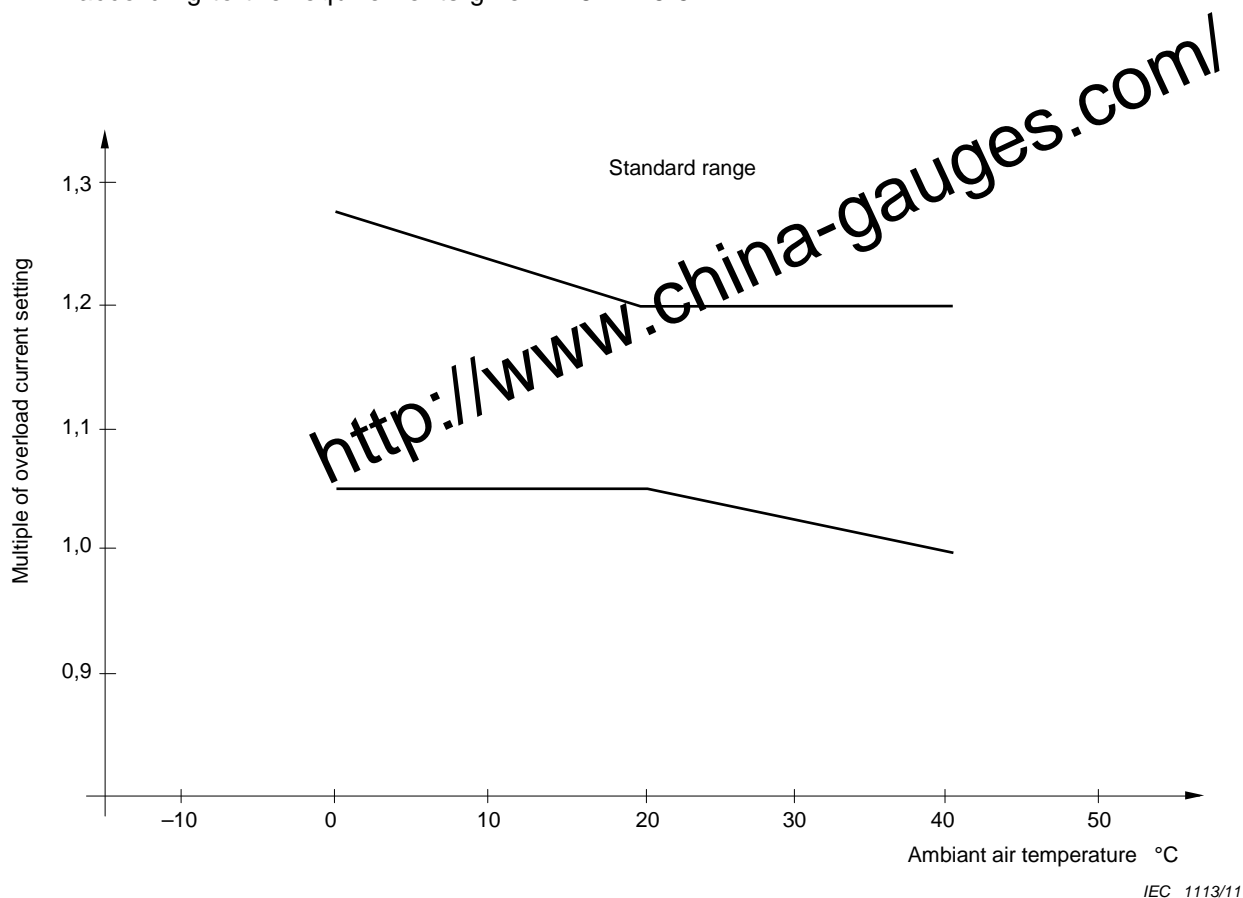

Figure 4 – Multiple of current setting limits for ambient air temperature compensated time-delay overload relays

9.3.4 Performance under short-circuit conditions

This subclause specifies test conditions for verification of compliance with the requirements of 8.2.5.1. Specific requirements regarding test procedure, test sequence, condition of equipment after the test and types of co-ordination are given in 9.3.4.1 and 9.3.4.3.

9.3.4.1 General conditions for short-circuit tests

General conditions for short-circuit tests are as follows:

- "O" operation: as a pre-test condition, the controller/starter shall be sustained in the ON-state by a dummy motor load. The pre-test current may be held at any arbitrary low level of current that is greater than the minimum load current of the controller/starter. The short-circuit current is applied to the controller/starter by closing the shorting switch. The SCPD shall interrupt the short-circuit current and the controller/starter shall withstand the let-through current;
- "CO" operation for direct on-line equipment.

Initial case temperature shall not be less than 40 °C. In some cases, it may be impossible to pre-heat the EUT and maintain the initial case temperature at a test site that is fitted for short-circuit testing only. In these cases, the manufacturer and user may agree to test the EUT at ambient temperature. If used, the lower temperature shall be recorded in the test report.

9.3.4.1.1 General requirements for short-circuit tests

The general requirements of 8.3.4.1.1 of IEC 60947-1:2007 apply with the following modification.

The enclosure shall be in accordance with the manufacturer specifications. In case of multiple enclosure options are provided, the enclosure with the smallest volume shall be taken.

If devices tested in free air may also be used in enclosures, they shall be additionally tested in the smallest of such enclosures stated by the manufacturer. For devices tested only in free air, information shall be provided to indicate as not suitable for use in an individual enclosure.

9.3.4.1.2 Test circuit for the verification of short-circuit ratings

The test circuit of 8.3.4.1.2 of IEC 60947-1:2007 shall be modified and wired as shown in Figure I.1. The dummy motor load and the shorting switch shall have the following characteristics:

- a) the dummy load shall be a squirrel cage motor with the characteristics that are given in 8.2.4.3;
- b) the shorting switch (not a part of the EUT) shall be capable of making and carrying the short-circuit current with no tendency to interfere with the process of applying the short-circuit current (for example bounce or other intermittent openings of the contacts).

9.3.4.1.3 Power factor of the test circuit

Subclause 8.3.4.1.3 of IEC 60947-1:2007 applies.

9.3.4.1.4 Vacant

9.3.4.1.5 Calibration of the test circuit

Subclause 8.3.4.1.5 of IEC 60947-1:2007 applies.

9.3.4.1.6 Test procedure

Subclause 8.3.4.1.6 of IEC 60947-1:2007 applies with the following additions:

The controller or the starter and its associated SCPD shall be mounted and connected as in normal use. They shall be connected in the circuit using a maximum of 2,4 m of cable (corresponding to the operational current of the controller or starter) for each main circuit.

If the SCPD is separate from the controller or starter, it shall be connected to the starter using the cable specified above (the total length of cable shall not exceed 2,4 m).

Three phase tests are considered to cover single-phase applications.

The time-line for the test sequence is shown in Figure I.2.

- a) The test is started with the shorting switch in the open position (time T0).
- b) The test voltage is then applied and the dummy motor load shall limit the current to a level that is, at least, sufficient to maintain the controller in the ON-state (time T1).
- c) At any arbitrary time after the current through the controller has stabilized, the shorting switch may then be closed at random and thereby establish a short-circuit current path through the EUT (time T2) which shall be cleared by the SCPD (time T3).

9.3.4.1.7 Vacant

9.3.4.1.8 Interpretation of records

Subclause 8.3.4.1.8 of IEC 60947-1:2007 applies.

9.3.4.2 Vacant

9.3.4.3 Conditional short-circuit current of controllers and starters

The controller or starter and the associated SCPD shall be subjected to the tests given in 9.3.4.3.1.

No further testing is required for bypassed controllers with independent components.

Bypassed controllers having independent components shall be submitted to two separate short-circuit tests in accordance with 9.3.4.

- a) Test 1: The test is conducted with the semiconductors in the conducting mode and with the bypass contacts open. This is intended to simulate short-circuit conditions occurring while starting in a mode that is controlled by the semiconductors.
- b) Test 2: The test is conducted with the semiconductors bypassed with the bypass contacts closed. This is intended to simulate short-circuit conditions occurring while the semiconductors of the EUT are bypassed.

The tests are to be conducted under conditions corresponding to the maximum I_e and the maximum U_e for utilization category AC-53a.

When the same semiconductor component is used for several ratings, the test shall be performed under the conditions corresponding to the highest rated current I_e .

The controls shall be energized by a separate electrical supply at the specified control voltage. The SCPD used shall be as stated in 8.2.5.1.

If the SCPD is a circuit-breaker with an adjustable current setting, the test shall be carried out with the circuit-breaker adjusted to the maximum setting for type 1 co-ordination and to the maximum declared setting for type 2 co-ordination.

During the test, all openings of the enclosure shall be closed as in normal service and the door or cover secured by the means provided.

A starter covering a range of motor ratings and equipped with interchangeable overload relays shall be tested with the overload relay with the highest impedance and the overload relay with the lowest impedance together with the corresponding SCPDs.

The O operation shall be performed with the sample at I_q .

9.3.4.3.1 Test at the rated conditional short-circuit current I_q

The circuit shall be adjusted to the prospective short-circuit current I_q equal to the rated conditional short-circuit current.

If the SCPD is a fuse and the test current is within the current-limiting range of the fuse then, if possible, the fuse shall be selected to allow the maximum value of cut-off current (I_c) (according to Figure 3 of IEC 60269-1:2006) and the maximum let-through I^2t values.

Except for direct on-line controllers or starters, one breaking operation of the SCPD shall be performed with the controller or starter in the full-ON state and the SCPD closed; the short-circuit current shall be switched on by a separate switching device.

For direct on-line controllers or starters, one breaking operation of the SCPD shall be performed by closing the controller or starter on to the short circuit.

9.3.4.3.2 Results to be obtained

The controller or starter shall be considered to have passed the tests at the prospective current I_q if the following conditions are met for the claimed type of co-ordination.

Both types of co-ordination

- a) The fault current has been successfully interrupted by the SCPD or the starter. In addition, the fuse or fusible element in solid connection between the enclosure and supply shall not have melted.
- b) The door or cover of the enclosure has not been blown open, and it is possible to open the door or cover. Deformation of enclosure is considered acceptable provided the degree of protection by the enclosure is not less than IP2X.
- c) There is no damage to the conductors or terminals and the conductors have not been separated from the terminals.
- d) There is no cracking or breaking of an insulating base to the extent that the integrity of mounting of a live part is impaired.

Type 1 co-ordination

- e) There has been no discharge of parts beyond the enclosure. Damage to the controller and overload relay is acceptable. The starter or the controller may be inoperative after the test.

Type 2 co-ordination

- f) No damage to the overload relay or other parts has occurred and no replacement of parts is permitted during the test. For hybrid controllers and starters welding of contacts is permitted, if they are easily separated (for example by a screwdriver) without significant deformation. In the case of welded contacts as described above, the functionality of the device shall be verified under the conditions of Table 11 for the declared utilization category by carrying out 10 operating cycles (instead of 3).
- g) The tripping of the overload relay shall be verified at a multiple of the current setting and shall conform to the published tripping characteristics, according to 5.7, both before and after the short-circuit test.
- h) The adequacy of the insulation shall be verified by a dielectric test on the controller or starter. The test voltage shall be applied as specified in 9.3.3.4.1 (4).

9.3.5 EMC tests

All emission and immunity tests are type tests, and shall be carried out under representative conditions, both operational and environmental, using the manufacturer's recommended wiring practices, and including any enclosures specified by the manufacturer.

A motor is required for the purpose of testing. The motor and its connections are auxiliary equipment necessary for the execution of the tests, but do not form part of the equipment under test. Except for the purposes of the harmonic emission test, it is not necessary to load the motor. If the motor used in any test is of lower power than the intended power range of the controller or starter, it shall be so stated in the test report. Tests are not required on the power output port. Unless otherwise specified by the manufacturer, the length of the connections to the motor shall be 3 m.

Test reports are to give all the relevant information relating to the tests (for example load conditions, cable dispositions, etc.). A functional description and a definition of specification limits for the acceptance criteria shall be provided by the manufacturer, and noted in the test report. The test report shall include any special measures that have been taken to achieve compliance, for example the use of shielded or special cables. A list of auxiliary equipment, which, together with the controller or starter, comprises the equipment necessary to comply with the immunity or emission requirements, shall also be included in the report. The tests shall be carried out at the rated supply voltage U_s and in a reproducible manner.

Form 1 controllers and starters, in which the power switching elements, for example thyristors, are not fully conducting during some or all steady-state modes of operation, shall be tested under conditions of minimum conduction chosen by the manufacturer to represent the operation of the controller or starter at the points of sustained maximum emission or susceptibility (see 9.3.5.1).

9.3.5.1 EMC emission tests

9.3.5.1.1 Condition for the emission tests

All emission tests shall be performed under steady-state conditions.

Emission measurements during the starting time with the existing measuring equipment are under consideration.

NOTE The scanning time for frequency analysis is often much longer than the starting time. According to the current IEC 61000-4 series of standards, relevant result of measurement can only be obtained in steady-state conditions.

9.3.5.1.2 Conducted radio frequency emission test

Descriptions of the test, the test method and the test set-up are given in CISPR 11.

It shall be sufficient to test two samples from a range of controllers of different power ratings which represent the highest and lowest power ratings of the range.

The emission shall not exceed the levels given in Table 19.

The addition of high-frequency common mode filtering in the main power connections may cause unacceptable reductions in motor starting torque, or render invalid the concept of unearthed or high impedance earthed distribution systems, as employed within process industries, with implications for system safety.

If, in order to fulfil the emission levels given in Table 19, filters are necessary but are not used for the above reasons, other precautions shall be taken in order not to exceed the emission levels given in this table.

Table 19 – Terminal disturbance voltage limits for conducted radio-frequency emission

Frequency range MHz	Environment A ^a rated input power ≤ 20 kVA		Environment A ^{a, b} rated input power > 20 kVA		Environment B ^a	
	Quasi-peak dB (μV)	Average dB (μV)	Quasi-peak dB (μV)	Average dB (μV)	Quasi-peak dB (μV)	Average dB (μV)
0,15 to 0,5	79	66	100	90	56 to 66 (decrease with log of frequency)	56 to 46 (decrease with log of frequency)
0,5 to 5	73	60	86	76	56	46
5 to 30	73	60	80 to 73 (decrease with log of frequency)	80 to 60 (decrease with log of frequency)	60	50

^a Defined by IEC 60947-1.

^b These limits apply to equipment with a rated input current > 20 kVA. The manufacturer and/or supplier shall provide information on installation measures that can be used to reduce emissions from the installed equipment. In particular, it shall be indicated that this equipment is intended to be powered a dedicated power transformer or generated and not LV overhead power lines.

Limits in accordance with CISPR 11, Group 1.

9.3.5.1.3 Radiated radio frequency emission test

Descriptions of the test, the test method, and the test set-up are given in CISPR 11.

NOTE In the USA, digital devices with power consumption less than 6 nW are exempt from RF emission tests.

It shall be sufficient to test a single representative sample from a range of controllers or starters of different power ratings.

The emission shall not exceed the levels given in Table 20.

Table 20 – Radiated emissions test limits

Frequency range MHz	Environment A ^a Quasi-peak dB (μV)			Environment B ^a Quasi-peak dB (μV)	
	at 30 m	at 10 m	at 3 m	at 10 m	at 3m
30 to 230	30	40	50	30	40
230 to 1 000	37	47	57	37	47

^a Tests may be carried out at 3 m distance only to small equipment (equipment, either positioned on a table top or standing on the floor which, including its cables fits in a cylindrical test volume of 1,2 m in diameter and 1,5 m above the ground plane).

9.3.5.2 EMC immunity tests

Where a range of controllers or starters comprise similarly configured control electronics, within similar frame sizes, it is only necessary to test a single representative sample of the controller or starter as specified by the manufacturer.

9.3.5.2.1 Electrostatic discharges

Subclause 8.4.1.2.4 of IEC 60947-1:2007 applies with the following additions.

Tests are not required on power terminals. Discharges shall be applied only to points which are accessible during normal usage.

The controller or starter shall comply with performance criterion 2 of Table 15.

Tests are not possible if the controller or starter is an open frame or chassis unit, or of degree of protection IP00. In that case, the manufacturer shall attach a label to the unit advising of the possibility of damage due to static discharge.

9.3.5.2.2 Radio-frequency electromagnetic field

For conducted immunity tests, 8.4.1.2.6 of IEC 60947-1:2007 applies with the following addition.

- The performance criterion 1 of Table 15 applies.

For radiated radio-frequency electromagnetic field immunity tests, 8.4.1.2.3 of IEC 60947-1:2007 applies with the following addition.

- The performance criterion 1 of Table 15 applies.

9.3.5.2.3 Fast transients (5/50 ns)

Subclause 8.4.1.2.4 of IEC 60947-1:2007 applies with the following additions.

Terminals for control and auxiliary circuits intended for the connection of conductors which extend more than 3 m shall be tested.

The controller or starter shall comply with performance criterion 2 of Table 15.

9.3.5.2.4 Surges (1,2/50 µs-8/20 µs)

Subclause 8.4.1.2.5 of IEC 60947-1:2007 applies.

The controller or starter shall comply with performance criterion 2 of Table 15.

9.3.5.2.5 Harmonics and commutation notches

No requirement, the test levels are under study for the future.

9.3.5.2.6 Voltage dips and short-time interruptions

Subclause 8.4.1.2.8 of IEC 60947-1:2007 applies with the performance criterion 3 of Table 15 except for 0,5 cycle and 1 cycle for which the performance criterion 2 of Table 15 applies.

9.3.6 Routine and sampling tests

Routine tests are tests to which each individual controller or starter is subjected, during or after manufacture, to verify that it complies with the stated requirements.

9.3.6.1 General

Routine or sampling tests shall be carried out under the same, or equivalent conditions to those specified for type tests in the relevant parts of 9.1.2. However, the limits of operation in 9.3.3.2 may be verified at the prevailing ambient air temperature and on the overload relay alone, but a correction may be necessary to allow for the normal ambient conditions.

9.3.6.2 Operation and operating limits

The 2 following tests shall be made.

- 1) Functionality shall be verified by a blocking and commutating capability test according to Table 12.

Two operating cycles are required, one at 85 % U_e with 85 % U_s , and one at 110 % U_e with 110 % U_s . No loss of functionality as specified by the manufacturer is permitted.

- 2) It shall be verified that the equipment operates according to the requirements of 8.2.1.5.

Tests shall be made to verify the calibration of relays. In the case of a time-delay overload relay, this may be a single test with all poles equally energized at a multiple of the current setting, to check that the tripping time conforms (within tolerances) to the curves supplied by the manufacturer. For under-current relays, stall relays and jam relays, tests shall be carried out to verify the proper operation of these relays (see 8.2.1.5.3, 8.2.1.5.4 and 8.2.1.5.5).

9.3.6.3 Dielectric tests

The metal foil need not be applied. The tests shall be conducted on dry and clean controllers and starters.

Verification of dielectric withstand may be performed before final assembly of the device (that is, before connecting sensitive devices such as filter capacitors).

- (1) Impulse withstand voltage

Subclause 8.3.3.4.2 1) of IEC 60947-1:2007 applies.

- (2) Power-frequency withstand voltage

Subclause 8.3.3.4.2 2) of IEC 60947-1:2007 applies.

- (3) Combined impulse voltage and power-frequency withstand voltage

The tests of items (1) and (2) above may be replaced by a single power-frequency withstand test where the peak value of the sinusoidal wave corresponds to the value stated in items (1) or (2), whichever is the higher.

Annex A (normative)

Marking and identification of terminals

A.1 General

The purpose of identifying terminals is to provide information regarding the function of each terminal, or its location with respect to other terminals, or for other use.

A.2 Marking and identification of terminals of semiconductor controllers and starters

A.2.1 Marking and identification of terminals of main circuits

The terminals of the main circuits shall be marked by single figure numbers and an alphanumeric system.

Table A.1 – Main circuit terminal markings

Terminals	Markings
Main circuit	1/L1-2/T1
	3/L2-4/T2
	5/L3-6/T3
	7/L4-8/T4

For particular types of controllers or starters (see 5.2.5.3), the manufacturer shall provide the wiring diagram.

A.2.2 Marking and identification of terminals of control circuits

A.2.2.1 Control circuit power supply terminals

Under consideration.

A.2.2.2 Control circuit input/output signal terminals

Under consideration.

A.2.3 Marking and identification of auxiliary circuits

The terminals of auxiliary circuits shall be marked or identified on the diagrams by two figure numbers:

- the unit is a function number;
- the figure of the tens is a sequence number.

The following examples illustrate such a marking system:

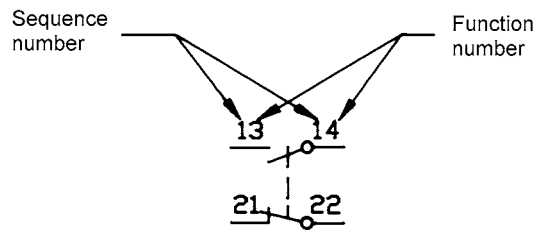

A.2.3.1 Function number

Function numbers 1, 2 are allocated to circuits with break contacts and function numbers 3, 4 to circuits with make contacts.

NOTE 1 The definitions for make contacts and break contacts are given in 2.3.12 and 2.3.13 of IEC 60947-1:2007.

Examples:

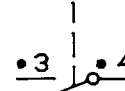
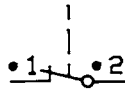

NOTE 2 The dots in the above examples take the place of the sequence numbers, which should be added appropriately to the application.

The terminals of circuits with change-over contact elements shall be marked by the function numbers 1, 2 and 4.

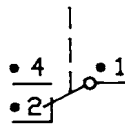

Function numbers 5 and 6 (for break contacts) and 7 and 8 (for make contacts) are allocated to terminals of auxiliary circuits containing auxiliary contacts with special functions.

Examples:

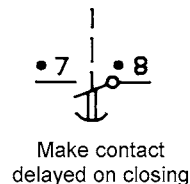
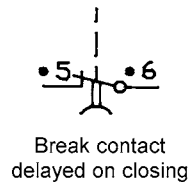

The terminals of circuits with change-over contact elements with special functions shall be marked by function numbers 5, 6 and 8.

Example:

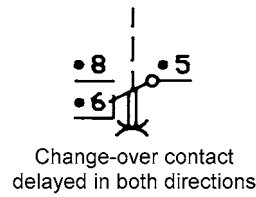

A.2.3.2 Sequence number

Terminals belonging to the same contact element shall be marked by the same sequence number.

All contact elements having the same function shall have different sequence numbers.

The sequence number may be omitted from the terminals only if additional information provided by the manufacturer clearly gives such a number.

Examples:

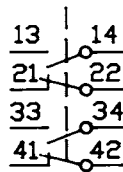

Four contact elements

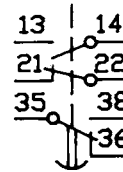

Three contact elements

A.3 Marking and identification of terminals of overload relays

The terminals of the main circuits of overload relays shall be marked in the same manner as the terminals of the main circuits of controllers and starters (see A.2.1).

The terminals of the auxiliary circuits of overload relays shall be marked in the same manner as the terminals of the auxiliary circuits of controllers and starters with specified functions (see A.2.3).

The sequence number shall be 9; if a second sequence number is required, it shall be 0.

Examples:

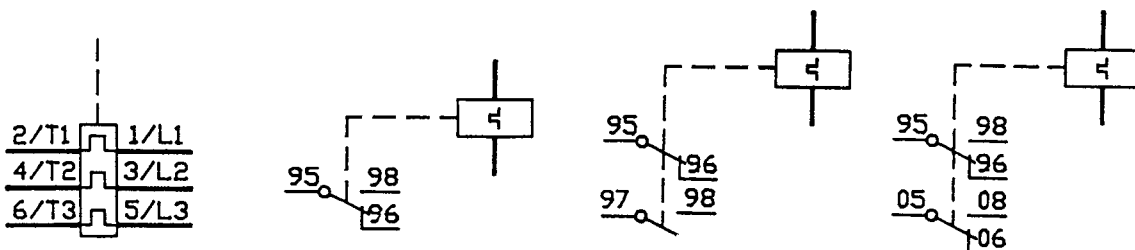

Alternatively, terminals may be identified on the wiring diagram supplied with the device.

Annex B

Vacant

<http://www.china-gauges.com/>

Annex C (normative)

Co-ordination at the crossover current between the starter and associated SCPD

C.1 Scope of this annex

This annex states the method of verifying the performance of overload protective devices of starters when the starter is associated with a SCPD:

C.2 General and definitions

C.2.1 General

This annex states different methods of verifying the performance of starters and the associated SCPD(s) at currents below and above the intersection I_{co} of their respective time-current characteristics, provided by the starter and SCPD manufacturer(s), and the corresponding types of co-ordination described in 8.2.5.1.

Co-ordination at the crossover current between the starter and the SCPD can be verified either by the direct method with the special test of Clause C.3 or, for type "2" co-ordination, by the indirect method as in Clause C.6.

C.2.2 Terms and definitions

C.2.2.1

crossover current

I_{co}

current corresponding to the crossover point of the mean or published curves representing the time-current characteristics of the overload relay and the SCPD respectively

NOTE The mean curves are the curves corresponding to the average values calculated from the tolerances on the time-current characteristics given by the manufacturer.

C.2.2.2

test current

I_{cd}

test current greater than I_{co} , tolerances included, designated by the manufacturer and verified by the requirements given in Table C.1

C.2.2.3

time-current withstand characteristic capability of controllers/starters

locus of the currents a controller/starter can withstand as a function of time

C.3 Condition for the test for the verification of co-ordination at the crossover current by a direct method

The starter and its associated SCPD shall be mounted and connected as in normal use. All the tests shall be performed starting from the cold state.

C.4 Test currents and test circuits

The test circuit shall be according to 8.3.3.5.2 of IEC 60947-1:2007 except that the oscillatory transient voltage need not be adjusted. The currents for the tests shall be as follows:

- (i) $0,75 I_{co} \begin{smallmatrix} 0 \\ -5 \end{smallmatrix}$ % and
- (ii) $1,25 I_{co} \begin{smallmatrix} +5 \\ 0 \end{smallmatrix}$ %.

The power factor of the test circuit shall be in accordance with Table 11. In the case of small relays having a high resistance, inductors should be mainly used in order to have a value of power factor as low as possible. The recovery voltage shall be 1,05 times the rated operational voltage.

The SCPD shall be as stated in 8.2.5.1 and of the same rating and characteristics as used in the tests of 9.3.4.3.

The starter shall be connected so that it opens when the overload relay operates. Coils, if any, shall be energized from a separate source at the rated control supply voltage.

C.5 Test procedure and results to be obtained

C.5.1 Test procedure

With the starter and the SCPD closed, the test currents stated in Clause C.4 shall be applied by a separate closing device. In each case the device tested shall be at room temperature.

After each test, it is necessary to inspect the SCPD, reset the overload relay and the release of the circuit-breaker, if necessary, or to replace all fuses if at least one of them has melted.

C.5.2 Results to be obtained

After the test at the lower current (i) in Clause C.4, the SCPD shall not have operated and the overload relay or release shall have operated to open the starter. There shall be no damage to the starter.

After the test at the higher current (ii) in Clause C.4, the SCPD shall have operated before the starter. The starter shall meet the conditions of 9.3.4.3.2 for the type of co-ordination stated by the manufacturer.

C.6 Verification of co-ordination at the crossover current by an indirect method

C.6.1 General

NOTE For type "1" co-ordination, the indirect method may be different from the method described in this annex and is under consideration. For this reason, the indirect method for the verification of co-ordination at the crossover point is only applicable for type "2" co-ordination.

The indirect method consists in verifying on a diagram (see Figure C.1) that the following conditions for the verification of co-ordination at the crossover current are met:

- the time-current characteristic of the overload relay/release, starting from cold state, supplied by the manufacturer, shall indicate how the tripping time varies with the current up to a value of at least I_{co} ; this curve has to lie below the time-current characteristic of the SCPD up to I_{co} ;
- I_{cd} of the starter, tested as in C.6.2, shall be higher than I_{co} ;

- the time-current withstand characteristic of the controller, tested as in C.6.3, shall be above the time-current characteristic (starting from cold state) of the overload relay up to I_{co} .

C.6.2 Test for I_{cd}

Subclause 9.3.4.1 applies with the following addition.

- Test procedure: the controller or starter shall make and break the test current (I_{cd}) for the number of operating cycles given in Table C.1. This is made without the SCPD in the circuit.

Table C.1 Test conditions

	U_r/U_e	$\cos \phi$	On-time (see Note 2) s	Off-time s	Number of operations
I_{cd}	1,05	See Note 1	0,05	See Note 3	3
NOTE 1 Power factor to be selected according to Table 16 of IEC 60947-1:2007.					
NOTE 2 Time may be less than 0,05 s provided that contacts, if any, are allowed to become properly seated before re-opening.					
NOTE 3 See Table 11.					

- Behaviour of controllers or starters during and after the I_{cd} test:
 - a) during the test, there shall be no permanent arcing, no flash-over between poles, no blowing of the fusible element in the earth circuit (see 9.3.4.1.2) and no welding of contacts;
 - b) after the test,
 - 1) the controller or starter shall operate correctly when switched by the applicable method of control;
 - 2) the dielectric properties of the controller and starter shall be verified by a dielectric test on the controller or starter using an essentially sinusoidal test voltage of twice the rated operational voltage U_e used for the I_{cd} test, with a minimum of 1 000 V. The test voltage shall be applied for 5 s, as specified in 9.3.3.4.1, items (2) c) i) and 2) c) ii).

C.6.3 Time-current characteristic withstand capability of controllers/starters

This characteristic is issued by the manufacturer at least up to I_{co} .

This characteristic is valid for overload currents, starting with the controller/starter at room temperature. The minimum cooling duration required by the controller/starter between two such overload tests should be stated by the manufacturer.

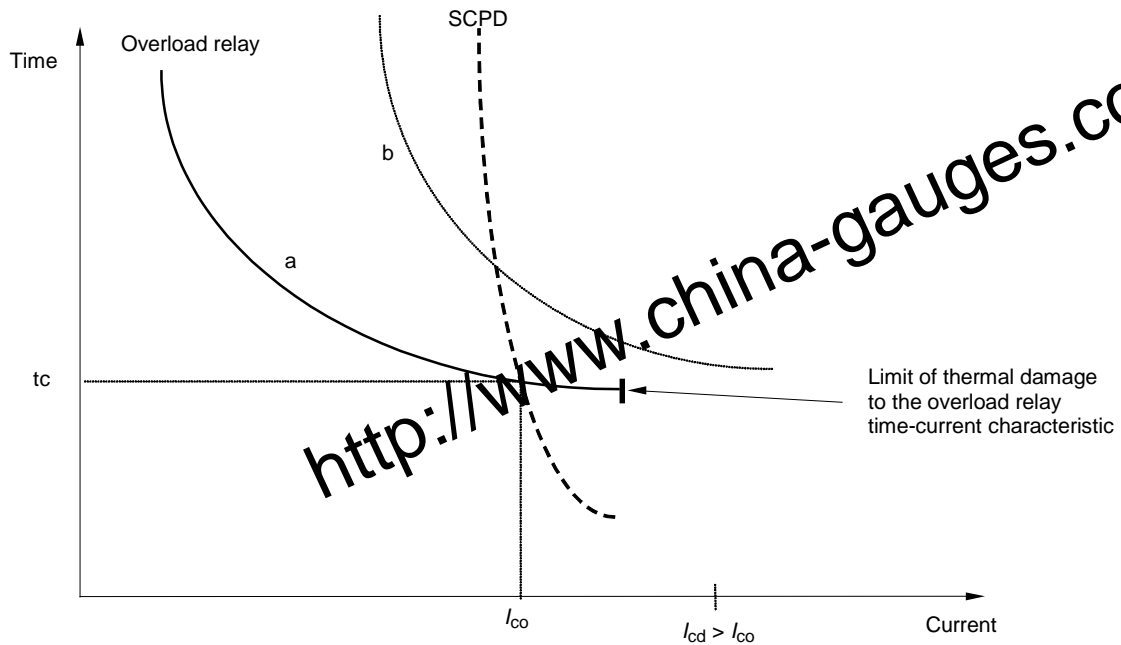

IEC 2201/06

Key

- a mean overload relay time-current characteristic from cold state
- b time-current characteristic withstand capability of controller

Figure C.1a – Co-ordination with fuse

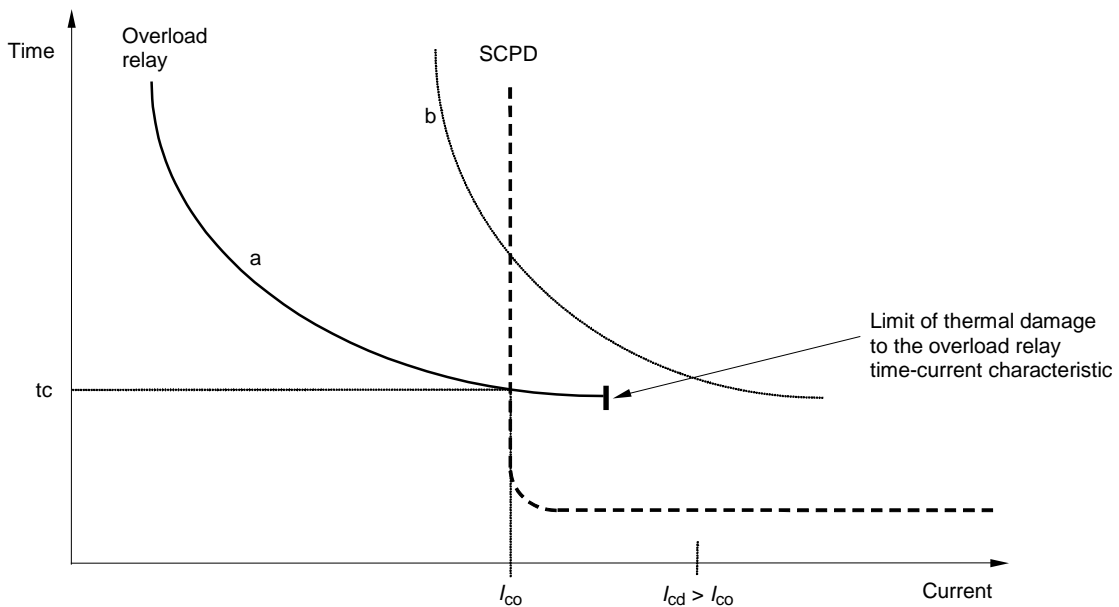

IEC 2202/06

Key

- a mean overload relay time-current characteristic from cold state
- b time-current characteristic withstand capability of controller

Figure C.1b – Co-ordination with circuit-breaker

Figure C.1 – Examples of time-current withstand characteristic

Annex D

Vacant

<http://www.china-gauges.com/>

Annex E

Vacant

<http://www.china-gauges.com/>

Annex F (informative)

Operating capability

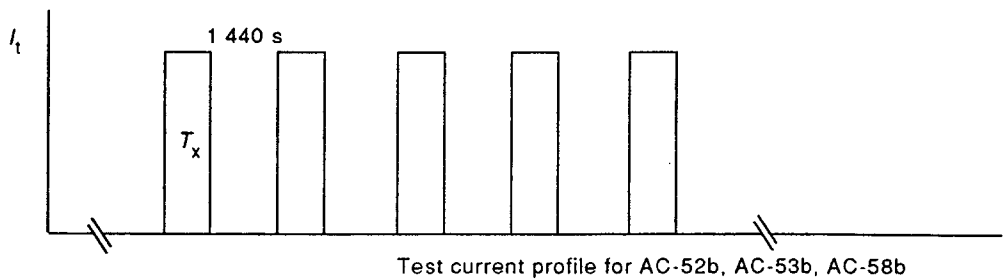
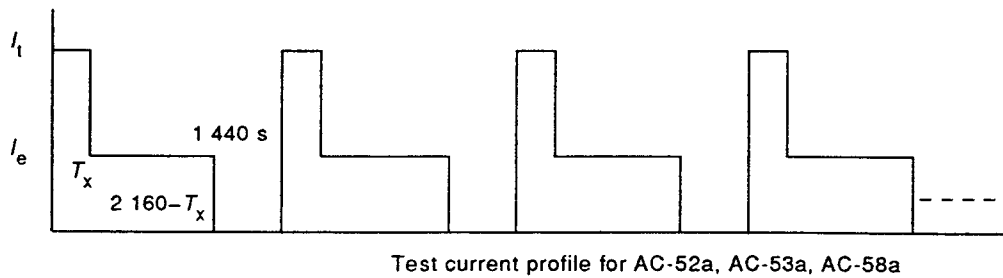
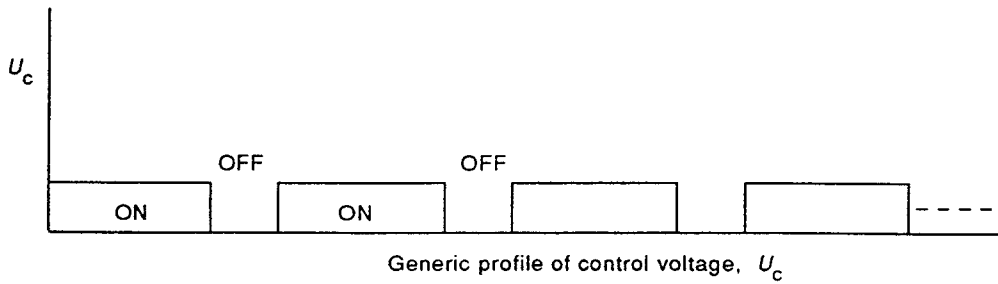
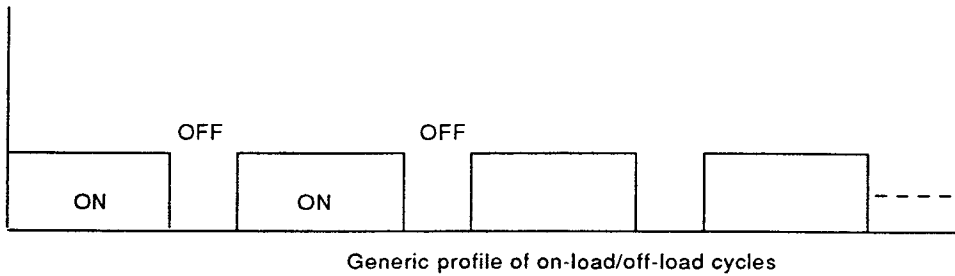
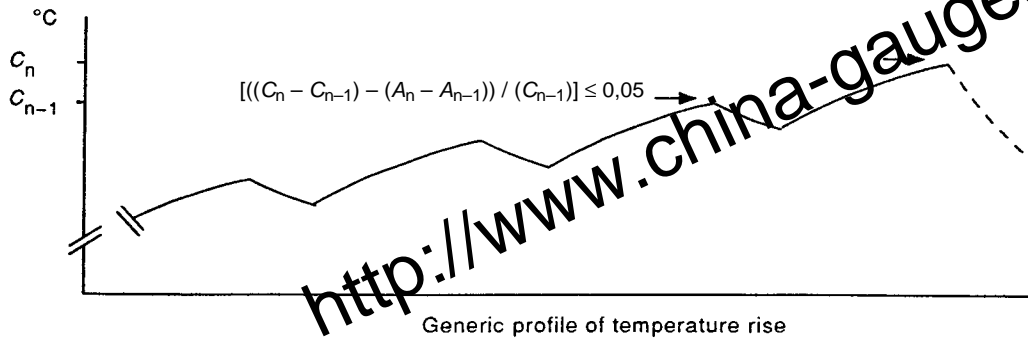

IEC 171/07

Figure F.1 – Thermal stability test profile

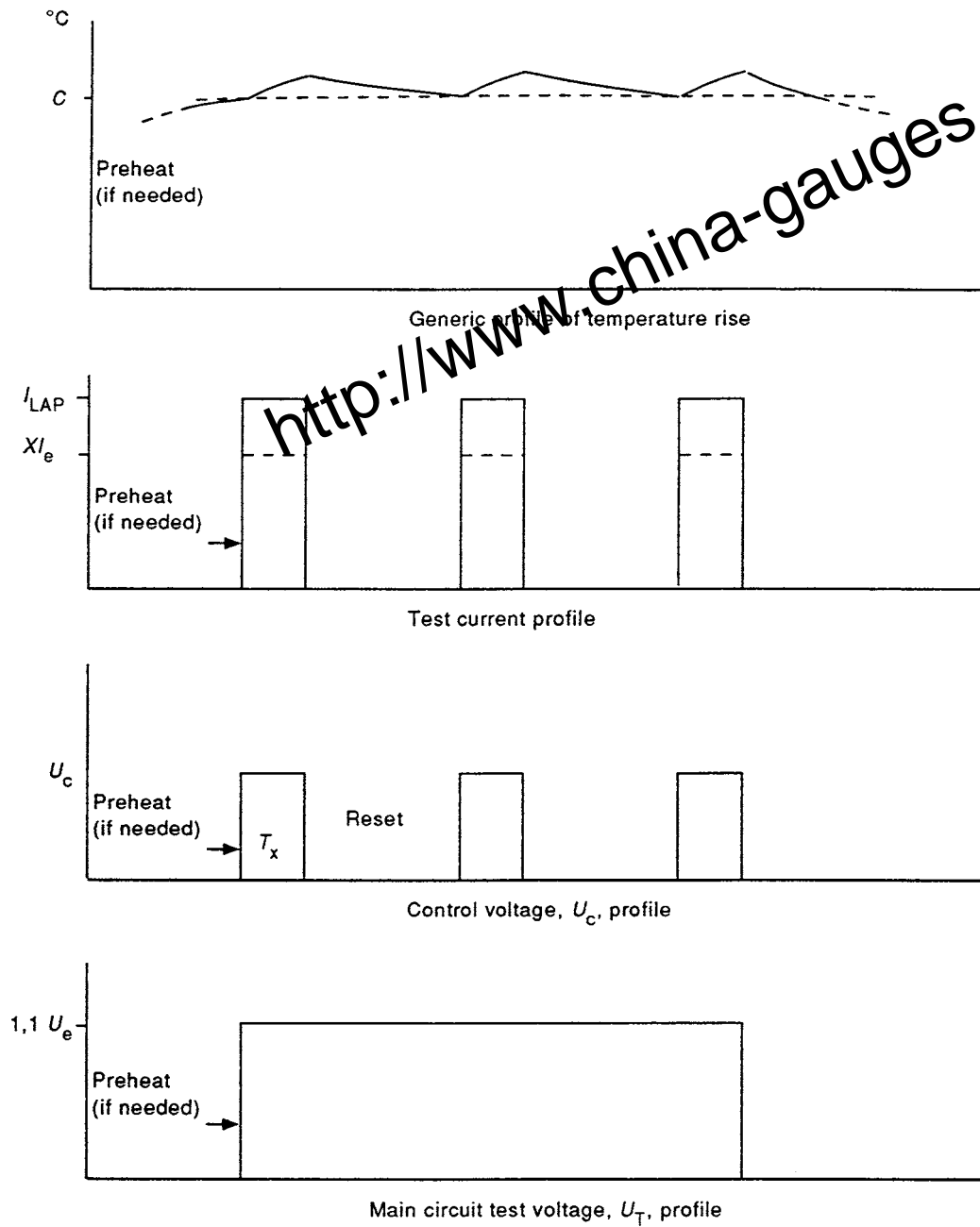

IEC 1114/11

Figure F.2 – Overload capability test profile

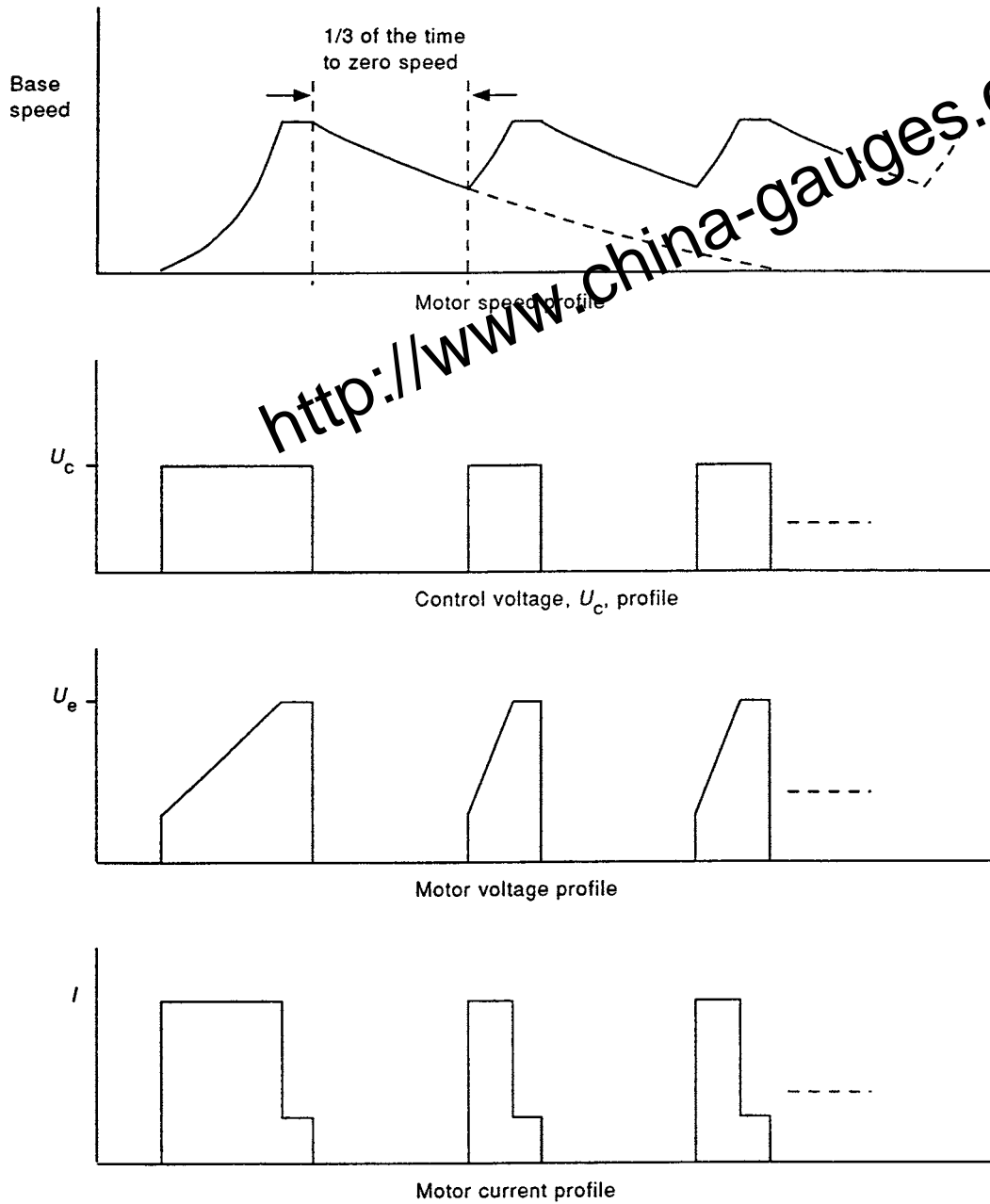

<http://www.china-gauges.com/>

IEC 1741/99

Figure F.3 – Blocking and commutating capability test profile

Annex G
(informative)

Examples of control circuit configurations

G.1 External control device (ECD)

G.1.1 Definition of an ECD

Any external element which serves to effect the control of the controller.

G.1.2 Diagrammatic representation of an ECD

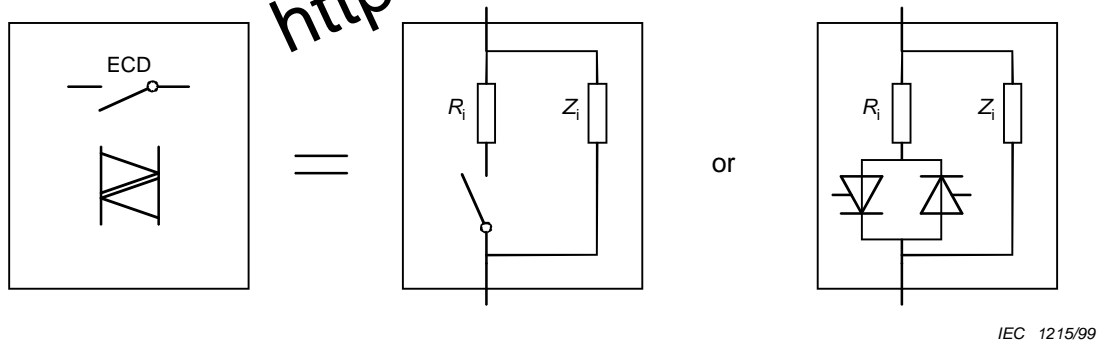

Figure G.1 – Diagrammatic representation of an ECD

G.1.3 Parameters of an ECD

- R_i : internal resistance
- Z_i : internal leakage impedance

NOTE In the case where ECD is a mechanical push button, R_i is often neglected and Z_i is often taken as ∞ .

G.2 Control circuit configurations

G.2.1 Controllers with external control supply

G.2.1.1 Single supply and control input

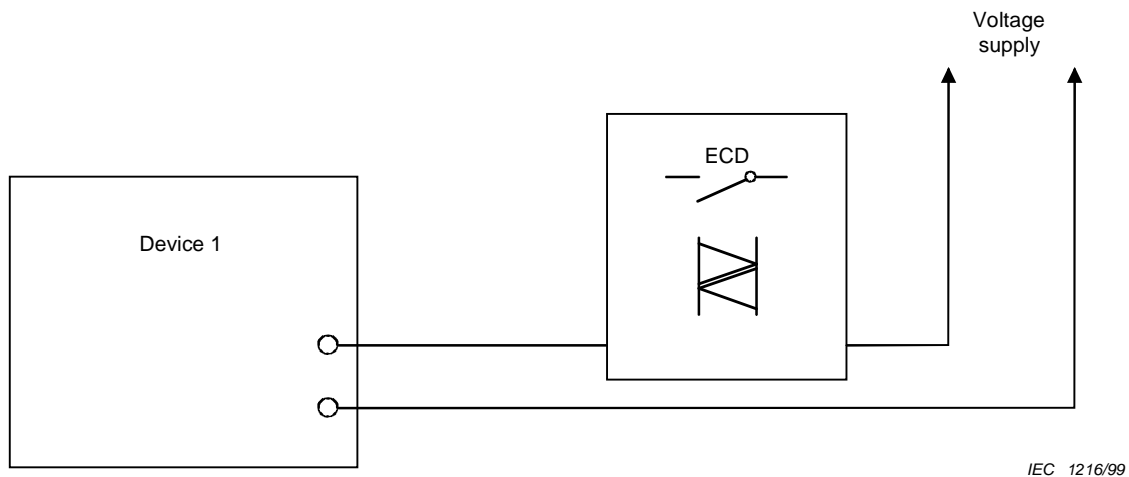

Figure G.2 – Single supply and control input

G.2.1.2 Separate supply and control inputs

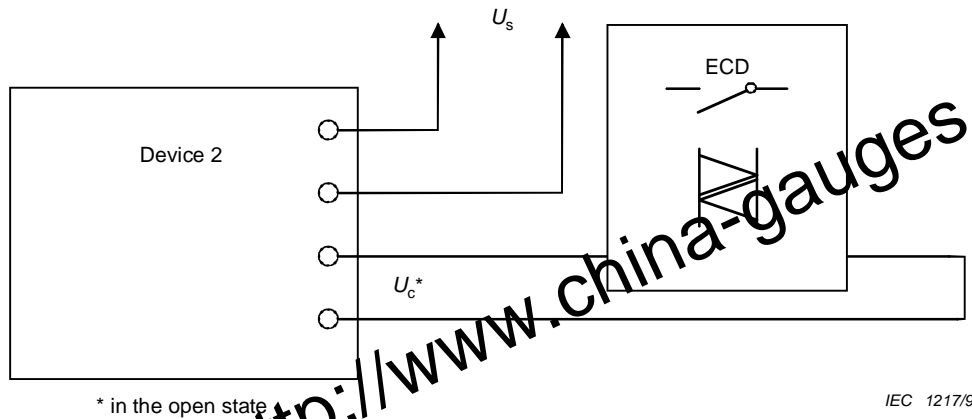

Figure G.3 – Single supply and control input

G.2.2 Controllers with an internal control supply and control input only

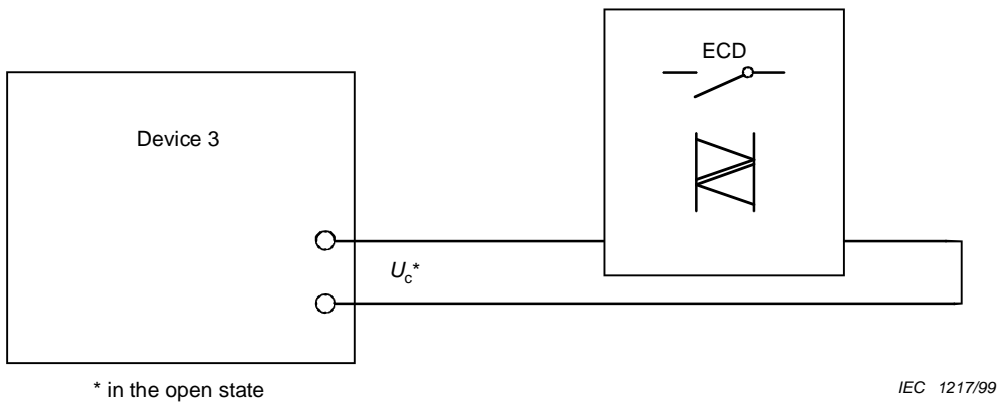

Figure G.4 – Controllers with an internal control supply and control input only

Annex H

Vacant

<http://www.china-gauges.com/>

Annex I
(normative)

**Modified test circuit for short-circuit testing
of semiconductor motor controllers and starters**

The standard circuits for short-circuit tests are illustrated in Figures 9 to 12 of IEC 60947-1:2007.

This diagram in Figure I.1 illustrates the modifications to only one phase of the standard test circuit for conducting short-circuit tests of semiconductor controllers. The modifications to each phase of the test circuit are identical for testing polyphase devices. The only modifications to be made are those shown in Figure I.1.

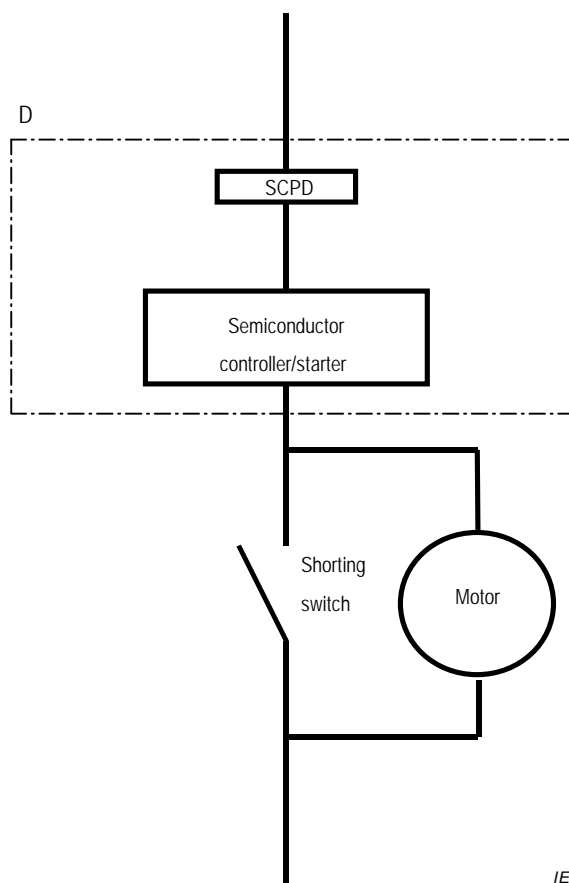

IEC 2346/01

Key

D Equipment under test (including connecting cables)

NOTE Outline includes metallic screen or enclosure.

Figure I.1 – Modified circuit for short-circuit testing of semiconductor devices

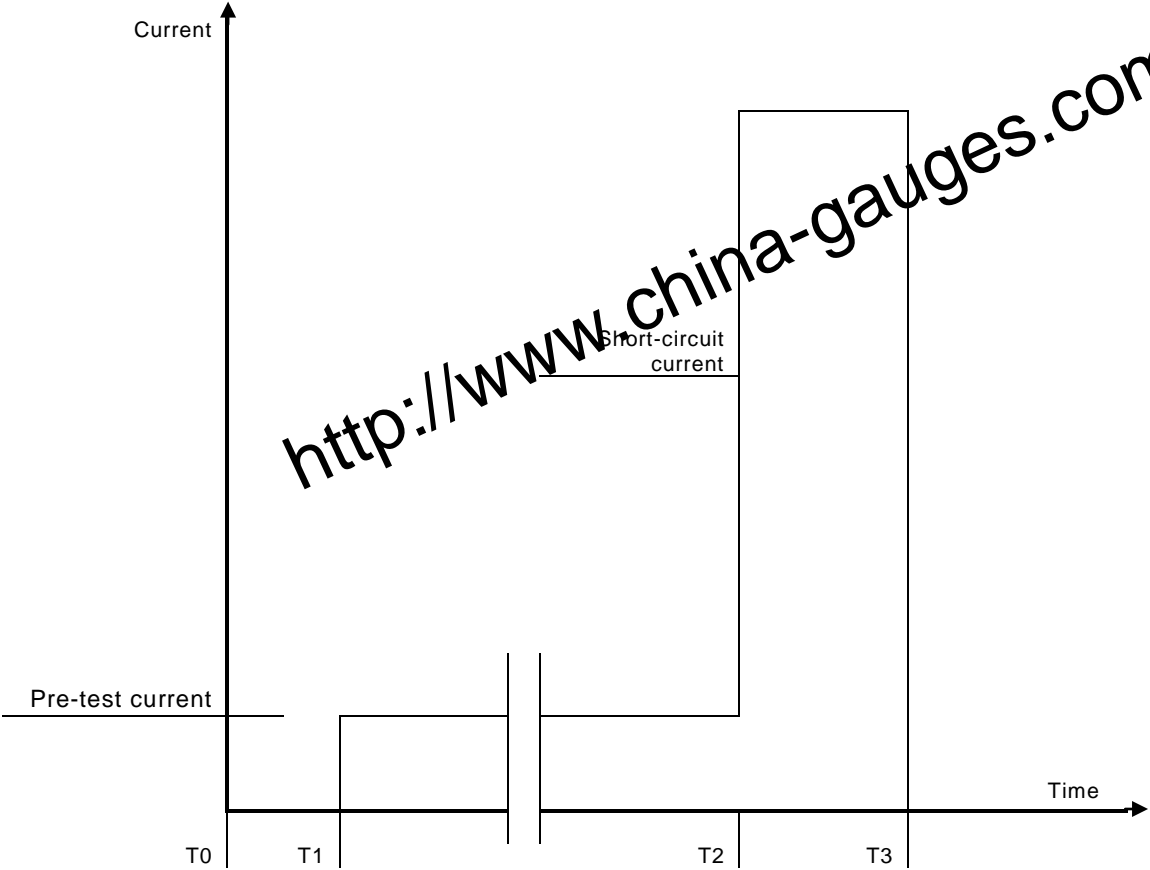

Key

- T0 shorting switch opens (9.3.4.1.6 a)
- T1 test circuit is energized (9.3.4.1.6 b)
- T2 shorting switch is closed (9.3.4.1.6 c)
- T3 SCPD clears the fault

IEC 1115/11

Figure I.2 – Time line for the short-circuit test of 9.3.4.1.6

Annex J
(informative)

Flowchart for constructing bypassed semiconductor controllers tests

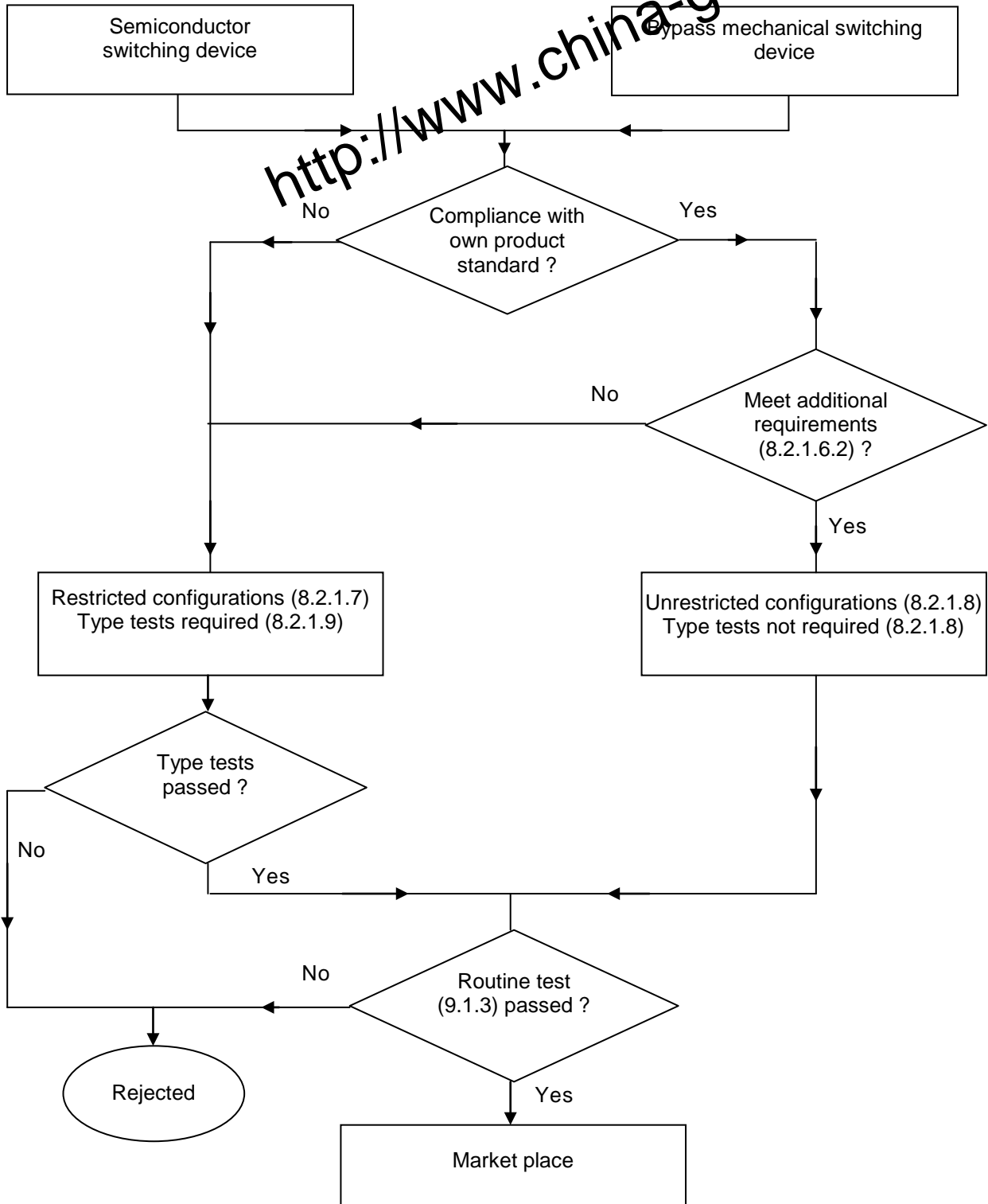

Annex K (normative)

Extended functions within electronic overload relays

K.1 Scope of this annex

K.1.1 General

This annex is intended to cover extended functions included in electronic overload relays not directly related to the overload protection.

All functions included in these overload relays not covered by this standard should comply with the requirements of relevant standards specifically covering these functions (for example IEC 60255 series, IEC 60947-5 series).

This annex applies only to electronic relays intended for use in a.c. circuits.

K.1.2 Residual current function

Devices reacting to residual differential currents are used as protective systems. Such devices are frequently used in conjunction with or as an integral part of electronic overload relays to detect residual current in the installation or the motor in order to provide additional protection against fire and other hazards which may develop as a result of an earth fault of a lasting nature which cannot be detected by the over-current protective function. The behaviour due to the presence of a d.c. component is not considered.

K.2 Terms and definitions

For the purposes of this annex, the following terms and definitions apply.

K.2.1

electronic overload relay with residual current (earth fault) function

multipole electronic relay which operates when the vectorial sum of the currents flowing in the main circuit has increased above a predetermined value in accordance with specified requirements

K.2.2

electronic overload relay with current or voltage asymmetry function

electronic overload relay which operates in the case of current or voltage magnitude unbalance in accordance with specified requirements

K.2.3

electronic overload relay with phase reversal function

multipole electronic overload relay which operates in the case of improper phase sequence at the line side of the starter in accordance with specified requirements

K.2.4

over-voltage sensitive electronic overload relay

electronic overload relay which operates in the case of overload and when the voltage has increased above a predetermined value in accordance with specified requirements

**K.2.5
inhibit current**

I_{ic}
fault current above which a switching device is not initiated to open

K.3 Classification of electronic overload relays

- a) Current and voltage asymmetry relay or release.
- b) Over-voltage relay or release.
- c) Residual current (earth fault) sensing relay or release.
- d) Phase reversal relay or release.

K.4 Type of relays

Type A: a Type A electronic overload relay is one that will initiate opening of the switching device at all levels of fault current.

Type B: a Type B electronic overload relay is one that will not initiate opening of the switching device above a set current level I_{ic} (inhibit current).

K.5 Performance requirements

K.5.1 Limits of operation of residual current electronic overload relays

A residual current overload relay, when associated with a switching device, shall operate to open the switching device according to the requirements given in Table K.1. For relays or releases with a residual current setting range, the limit of operation of the relay shall be verified at the lowest and highest settings.

Table K.1 – Operating time of residual current electronic overload relays

Multiples of residual current setting	Tripping time T_p ms
≤ 0,9	No trip
1,1	$10 < T_p \leq 1\ 000$

K.5.2 Limits of operation of residual current sensing electronic relays Type B

Subclause K.5.1 applies with the following addition.

A residual current sensing electronic relay Type B, when associated with a switching device, shall not initiate operation of the switching device, in the presence of a residual fault current, when the fault current in any phase reaches or exceeds 95 % of the set current level I_{ic} (see Clause K.4) and shall operate to open the equipment when the fault current in any phase is 75 % or less of I_{ic} .

K.5.3 Limits of operation of voltage asymmetry relays

A voltage asymmetry relay, when associated with a switching device, shall operate to open the switching device within 120 % of the time setting and shall operate to prevent the closing of the switching device when the voltage asymmetry is above 1,2 times the voltage asymmetry setting.

K.5.4 Limits of operation of phase reversal relays

A phase reversal relay, when associated with a switching device, shall permit the closing of the equipment when the voltage sequence of phases on the line side of the starter is the same as the voltage sequence setting. After interchanging two phases, the phase reversal relay shall prevent the closing of the equipment.

K.5.5 Limits of operation of current asymmetry relays

A current asymmetry relay, when associated with a switching device, shall operate to open the equipment within 120 % of the time setting when the current asymmetry is above 1,2 times the current asymmetry setting.

K.5.6 Limits of operation of over-voltage relays and releases

a) Operating voltage

An over-voltage relay or release, when associated with a switching device, shall operate to open the equipment and shall operate to prevent the closing of the equipment when the supply voltage is above the set value, if any, or above 110 % of the rated voltage of the relay or release for a defined duration.

b) Operating time

For a time-delay over-voltage relay or release, the time-lag shall be measured from the instant when the voltage reaches the operating value until the instant when the relay or release actuates the tripping device of the equipment.

K.6 Tests

K.6.1 Limits of operation of residual current sensing electronic relays Type A

The limits of operation shall be in accordance with K.5.1 and verified as follows.

For overload relays with an adjustable residual current setting, the test shall be made at the minimum and at the maximum current settings.

The test circuit shall be in accordance with Figure K.1. The test shall be made at a power factor $\geq 0,8$, at any convenient voltage and any convenient current.

The test circuit being calibrated at each of the values of the residual operating current specified in Table K.1, as applicable, and the switch S1 being in the closed position, the residual current is suddenly established by closing switch S2.

K.6.2 Limits of operation of residual current sensing electronic relays Type B

Subclause K.6.1 applies with the following addition.

The limits of operation under over-current condition shall be in accordance with K.5.2 and verified as follows.

The test shall be made with a three-phase load, the connections being made according to Figure K.1. The test shall be made at a power factor $\geq 0,8$, at any convenient voltage and any convenient current in the main poles.

For overload relays with an adjustable residual current setting, the test shall be made at the lowest setting.

For overload relays with an adjustable inhibit current setting I_{ic} , the test shall be made at the minimum and at the maximum I_{ic} settings.

The impedance Z1 is adjusted so as to let a current flow in the circuit equal to

- a) 95 % of the inhibit current I_{ic} ,

The switch S1 being in the closed position, the residual current is established by closing switch S2.

The overload relay shall not trip.

- b) 75 % of the inhibit current I_{ic} .

The switch S1 being in the closed position, the residual current is established by closing switch S2.

The overload relay shall trip.

K.6.3 Current asymmetry relays

The limits of operation shall be verified in accordance with K.5.5.

K.6.4 Voltage asymmetry relays

The limits of operation shall be verified in accordance with K.5.3.

K.6.5 Phase reversal relays

The limits of operation shall be verified in accordance with K.5.4.

K.6.6 Over-voltage relays

The limits of operation shall be verified in accordance with K.5.6.

K.7 Routine and sampling tests

Electronic overload relays with extended functions shall be, in addition to tests of 9.3.6, submitted to additional tests to verify the proper operation of their relevant additional functions, according to K.5.

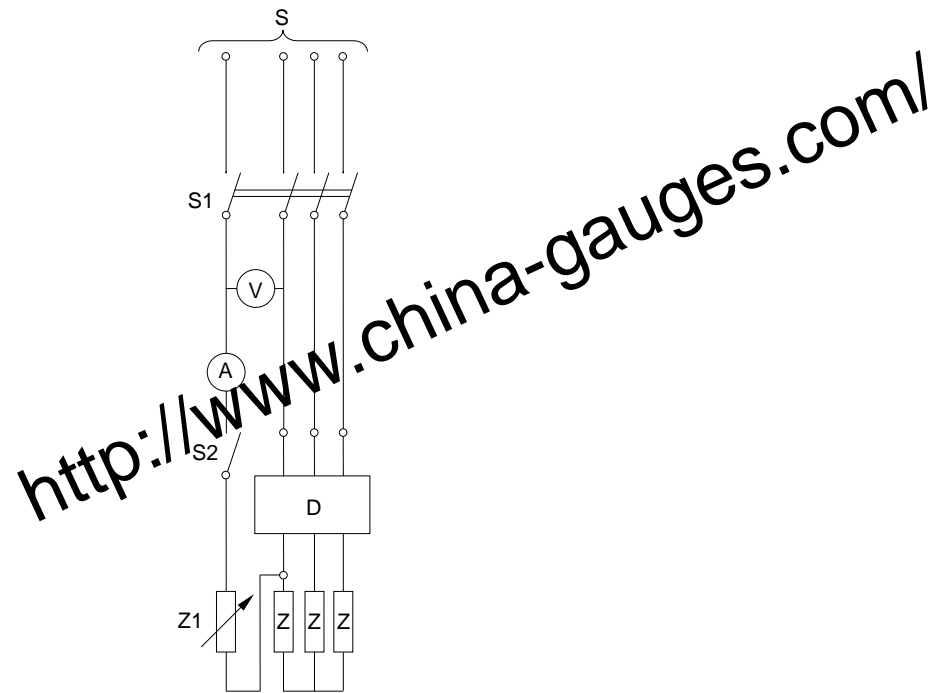

IEC 2203/06

Key

- S supply
- V voltmeter
- A ammeter
- S1 all-pole switch
- S2 single-pole switch
- D overload relay under test
- Z load circuit
- Z1 adjustable impedance

Figure K.1 – Test circuit for the verification of the operating characteristic of a residual current electronic overload relay

Bibliography

- IEC 60050-161:1990, *International Electrotechnical Vocabulary (IEV) – Chapter 161: Electromagnetic compatibility*
Amendment 1 (1997)
Amendment 2 (1998)
- IEC 60050-441:1984, *International Electrotechnical Vocabulary (IEV) – Chapter 441: Switchgear, controlgear and fuses*
- IEC 60146 (all parts) *Semiconductor convertors – General requirements and line commutated convertors*
- IEC 60255 (all parts), *Measuring relays and protection equipment*
- IEC 60417, *Graphical symbols for use on equipment*
- IEC 60947-5 (all parts), *Low-voltage switchgear and controlgear – Part 5-1: Control circuit devices and switching elements*
- IEC/TR 61000-2-1:1990, *Electromagnetic compatibility (EMC) – Part 2: Environment – Section 1: Description of the environment – Electromagnetic environment for low-frequency conducted disturbances and signalling in public power supply systems*
- IEC 61000-3-2:2005, *Electromagnetic compatibility (EMC) – Part 3-2: Limits – Limits for harmonic current emissions (equipment input current ≤ 16 A per phase)*
Amendment 1 (2008)
Amendment 2 (2009)
- IEC 61000-4-2:2008, *Electromagnetic compatibility (EMC) – Part 4-2: Testing and measurement techniques – Electrostatic discharge immunity test*
- IEC 61000-4-3:2006, *Electromagnetic compatibility (EMC) – Part 4-3: Testing and measurement techniques – Radiated radio-frequency electromagnetic field immunity test*
Amendment 1 (2007)
Amendment 2 (2010)
- IEC 61000-4-4:2004, *Electromagnetic compatibility (EMC) – Part 4-4: Testing and measurement techniques – Electrical fast transient/burst immunity test*
Amendment 1 (2010)
- IEC 61000-4-5:2005, *Electromagnetic compatibility (EMC) – Part 4-5: Testing and measurement techniques – Surge immunity test*
- IEC 61000-4-6:2008, *Electromagnetic compatibility (EMC) – Part 4-6: Testing and measurement techniques – Immunity to conducted disturbances, induced by radio-frequency fields*
- IEC 61000-4-11:2004, *Electromagnetic compatibility (EMC) – Part 4-11: Testing and measurement techniques – Voltage dips, short interruptions and voltage variations immunity tests*
- IEC 61131-2:2007, *Programmable controllers – Part 2: Equipment requirements and tests*

<http://www.china-gauges.com/>

British Standards Institution (BSI)

BSI is the national body responsible for preparing British Standards and other standards-related publications, information and services.

BSI is incorporated by Royal Charter. British Standards and other standardization products are published by BSI Standards Limited.

About us

We bring together business, industry, government, consumers, innovators and others to shape their combined experience and expertise into standards-based solutions.

The knowledge embodied in our standards has been carefully assembled in a dependable format and refined through our open consultation process. Organizations of all sizes and across all sectors choose standards to help them achieve their goals.

Information on standards

We can provide you with the knowledge that your organization needs to succeed. Find out more about British Standards by visiting our website at bsigroup.com/standards or contacting our Customer Services team or Knowledge Centre.

Buying standards

You can buy and download PDF versions of BSI publications, including British and adopted European and international standards, through our website at bsigroup.com/shop, where hard copies can also be purchased.

If you need international and foreign standards from other Standards Development Organizations, hard copies can be ordered from our Customer Services team.

Subscriptions

Our range of subscription services are designed to make using standards easier for you. For further information on our subscription products go to bsigroup.com/subscriptions.

With **British Standards Online (BSOL)** you'll have instant access to over 55,000 British and adopted European and international standards from your desktop. It's available 24/7 and is refreshed daily so you'll always be up to date.

You can keep in touch with standards developments and receive substantial discounts on the purchase price of standards, both in single copy and subscription format, by becoming a **BSI Subscribing Member**.

PLUS is an updating service exclusive to BSI Subscribing Members. You will automatically receive the latest hard copy of your standards when they're revised or replaced.

To find out more about becoming a BSI Subscribing Member and the benefits of membership, please visit bsigroup.com/shop.

With a **Multi-User Network Licence (MUNL)** you are able to host standards publications on your intranet. Licences can cover as few or as many users as you wish. With updates supplied as soon as they're available, you can be sure your documentation is current. For further information, email bsmusales@bsigroup.com.

BSI Group Headquarters

389 Chiswick High Road London W4 4AL UK

Revisions

Our British Standards and other publications are updated by amendment or revision.

We continually improve the quality of our products and services to benefit your business. If you find an inaccuracy or ambiguity within a British Standard or other BSI publication please inform the Knowledge Centre.

Copyright

All the data, software and documentation set out in all British Standards and other BSI publications are the property of and copyrighted by BSI, or some person or entity that owns copyright in the information used (such as the international standardization bodies) and has formally licensed such information to BSI for commercial publication and use. Except as permitted under the Copyright, Designs and Patents Act 1988 no extract may be reproduced, stored in a retrieval system or transmitted in any form or by any means – electronic, photocopying, recording or otherwise – without prior written permission from BSI. Details and advice can be obtained from the Copyright & Licensing Department.

Useful Contacts:

Customer Services

Tel: +44 845 086 9001

Email (orders): orders@bsigroup.com

Email (enquiries): cservices@bsigroup.com

Subscriptions

Tel: +44 845 086 9001

Email: subscriptions@bsigroup.com

Knowledge Centre

Tel: +44 20 8996 7004

Email: knowledgecentre@bsigroup.com

Copyright & Licensing

Tel: +44 20 8996 7070

Email: copyright@bsigroup.com